



# **MH3000 TEMPORARY RUN MANUAL**

# **Start Here**

**It is strongly recommend that you read this setup manual carefully before proceeding with the installation.**

**WARNING: The elevator controller must be installed by experienced field installation personnel. The field installation personnel must know and follow all the rules and regulations pertaining to the safe installation and running of elevators. Additional information for specific devices (such as the motors, door operator, etc.) is the responsibility of the manufacturers of those devices.**

**WARNING: This equipment is designed and built to comply with ANSI A17.1 and national electrical code and must be installed by a qualified contractor. It is the responsibility of the contractor to make sure that the final installation complies with all applicable local, state and national codes, and is installed safely.**

**WARNING: The 3 phase AC power supply to this equipment must come from a fused disconnect switch or circuit breaker which is sized in accordance with all applicable national, state and local electrical codes, in order to provide the necessary overload protection for the controller and motor. Incorrect motor branch circuit protection may create a hazardous condition.**

**WARNING: Proper grounding is vital for the safe operation of your system. Bring the ground wire to the ground stud that is labeled "GND" or "G". You must choose the proper conductor size. See national electrical code article 250-95, or the related local applicable code.**

## Controller Mounting

Mount the controller in a location that provides:

- Adequate support for the weight of the controller.
- Adequate lighting for installation and maintenance.
- Convenient access for the routing of required conduits and cables.
- Convenient access to other devices in the machine room.
- A minimum of vibration.

## Controller Environment

- Keep the machine room clean. Do not install the controller in a dusty area.
- Do not install the controller in a carpeted area, or area where static electricity is a problem.
- Keep room temperature between 0°C to 50°C (32°F to 122°F), and 95% non-condensing relative humidity. Extended high temperatures will shorten the life of electronic components. Provide adequate ventilation or air-conditioning as required.
- Avoid condensation on the equipment by keeping the controller away from sources of condensation and water (such as open windows) as these can create a hazardous condition and can damage the equipment.
- Do not install the controller in a hazardous location and where excessive amounts of vapors or chemical fumes may be present.
- Make sure power line fluctuations are within  $\pm 10\%$ .
- High levels of radio frequency emissions may cause interference with the controller microprocessor, resulting in unexpected and even dangerous results. This could be caused by hand-held communications devices used near the controller.

## Power and Motor Wiring

- All wiring must be done in accordance with the National Electric Code and any local codes that may apply.
- Wiring must be properly sized.
- Proper grounding is imperative to insure proper and safe operation of the equipment.
- Refer to the controller schematic (usually sheet "S") to connect building power and motor leads. Building power connects to terminals "L1, L2 & L3." The motor leads connect to terminals T1, T2, T3 and T4, T5, T6 when provided.
- The motor thermal overload must be connected as shown in Figure 1. If no thermal overload is available place a permanent jumper on terminals 18X & 38.

## Connecting the "Run Bug" without using the microprocessor (Preferred)

It is not necessary to use the controller and microprocessor to run the car for temporary service. If it is desirable to use the microprocessor for temporary service, see the section titled *Connecting the "Run Bug" using the microprocessor*.

Figure 1 indicates how the car may be run on temporary service, before the controller is fully installed. The fuse shown in Figure 1 is labeled "F4" on most controllers or "F5" when BORIS is used.

- Connect the hot (power) side of the "Run Bug" to the bottom of the fuse.
- Connect the wire from the **UP** button of the "Run Bug" to the hot (power) side of the solenoid that energizes when the car is to **UP LEVEL** and to one side of the motor thermal overload.
- Connect the other side of the motor thermal overload to terminal 18X.
- Connect the wire from the **DOWN** button of the "Run Bug" to the hot side of the solenoid that energizes when the car is to **DOWN LEVEL**.
- Connect the neutral sides of the two solenoids to terminal 35.

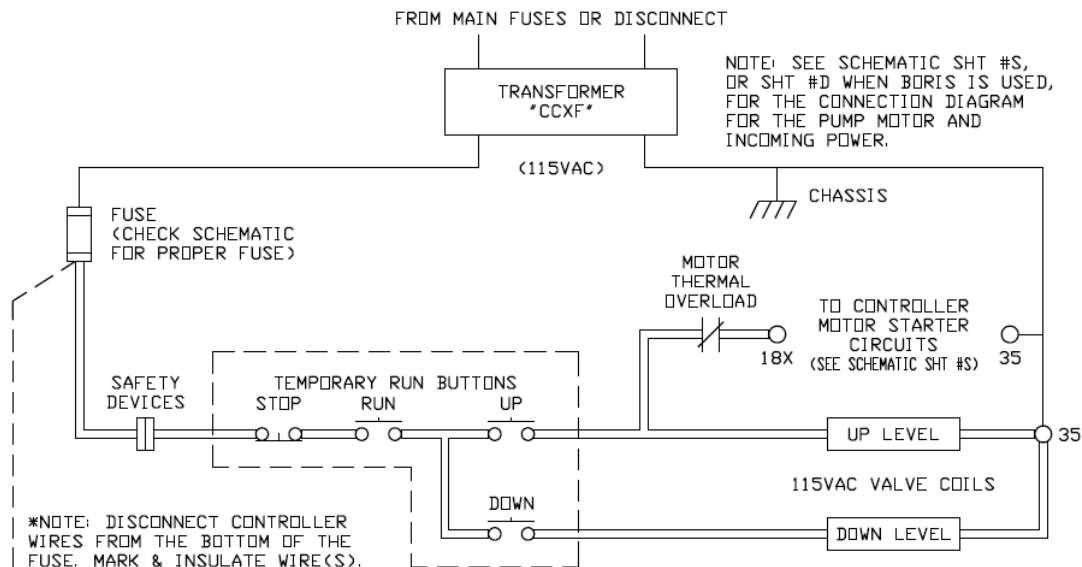

WARNING: CONNECT ANY AVAILABLE SAFETY DEVICES IN SERIES WITH THE RUN BUTTONS. USE EXTREME CAUTION WHEN OPERATING THE CAR.

**Figure 1**

**\*If a solid state starter is used, do not remove the wire from the bottom of the fuse as shown in the diagram.** Controller terminals 1 and 35 must have power to energize the solid state starter.

**WARNING: Note that other devices in the controller will have power.**

## Connecting the “Run Bug” using the microprocessor (Optional)

If it is desirable to use the controller and microprocessor to run the car on temporary service, the following procedure should be followed.

### Temporary Jumper Connections

- Check you schematic for the location of the safety string and jump out devices as necessary. Listed below is a list of devices that generally need to be jumped out. Compare this list to your controller and make adjustments if necessary.

**WARNING: It is important that all of these jumpers be removed before placing the car into permanent operation.**

- Additional “Run Bug” safety switches may be connected in place of some of the jumpers listed below. For example a run cord “stop switch” could be connected between terminals 1 & 1Y in place of a jumper.

DEVICE	Terminals to Jump
Pit switch	1-1Y
Car top Devices & Firefighter’s stop switch	2-3
Emergency Stop switch	3-4
Car Door Contact(s)	4-5
Hoistway Door Contacts	5B-5X
Up Normal Limit	6-14
Up Slowdown Limit	14X-18
Down Normal Limit	6-16
Down Slowdown Limit	16-19
Car Top Inspection Enable Switch	1-23W
Emergency power	1-EP (If provided)
Fire Sensors - Main Landing Recall	1-82
Fire Sensors – Alternate Landing Recall	1-82M
Aux. Contact in Main Disconnect (For BORIS)	1-L5 (If provided)

DIP Switch 3 on the microprocessor must be turned on to disable redundancy checking. This switch is located below the display on the circuit board that has the keypad. Turning on the switch will cause the fire service buzzer output to turn on and stay on until the switch is turned off.

**WARNING: DIP Switch 3 must be turned off prior to placing the elevator into operation! Failure to do so defeats critical safety devices required for safe operation of the elevator. Additionally, the fire service buzzer will sound continuously.**

If a BORIS (Battery Operated Rescue Initiation System) is used, make sure that the controller's power cord is connected to the controller's power cord receptacle. Do not use the BORIS unit until construction is complete and the elevator wiring has been tested.

## **Valve Solenoid Wiring**

Connect the valve solenoids as follows. Check the valve manufacturer's data sheets for additional information.

- The solenoid that energizes when the car is to **UP LEVEL** connects to terminals 14X & 33.
- The solenoid that energizes when the car is to run **UP FAST SPEED** connects to terminals 18 & 30.
- The solenoid that energizes when the car is to **DOWN LEVEL** connects to terminals 16 & 31.
- The solenoid that energizes when the car is to run **DOWN FAST SPEED** connects to terminals 19 & 32.

## “Run Bug” Connection

**WARNING: It is up to the operator to ensure safe movement of the car/platform. All Safety devices were disabled in the previous steps. It is solely up to the mechanic operating the “Run Bug” to ensure that no damage or personal injury will occur when moving the car. Use extreme caution when moving the car/platform.**

- Connect the hot (power) side of the “Run Bug” to terminal 1.
- Connect the **UP** button to terminal 25.
- Connect the **DOWN** button to terminal 24.
- Connect any additional safety devices as desired in place of temporary jumpers listed above.

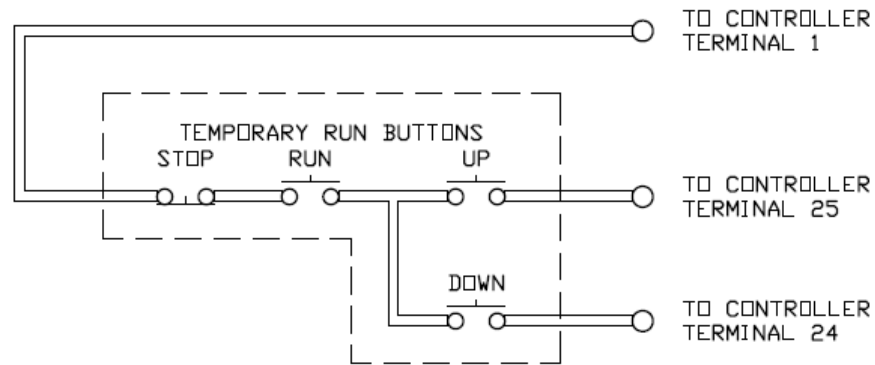

**Figure 2**

## Applying Power

- Remove fuses F1, F2 and F3. (F3 is not always used)
- Apply power to the controller.
- With a voltmeter check the voltage at terminals L1, L2 and L3. This voltage should match voltage on the controller data plate. If it is not, find out why and correct!
- Remove power from the controller and reinstall fuses F1, F2 and F3.
- Apply power to the controller. The microprocessor should be on and some inputs and relays may be on.
- The Phase Monitor (If provided) must be satisfied with the incoming power phasing. (If it is not, exchange any 2 wires to the monitor and recheck.) Input “RP” on the controller’s input module will be “high” when the phasing is correct.

- Use a voltmeter to check the voltage between terminals 1 and 35. This voltage should measure between 105VAC and 125VAC. If the voltage is outside of this range, turn off the power immediately and check that the incoming voltage to the controller is correct and that the primary of transformer "CCXF" is connected for the proper voltage.

## Running the Car

**WARNING: Ensure that the car can be moved safely without causing bodily harm or damage to the equipment.**

- Use the "Run Bug" to attempt a run in the up direction. Check that the controller's "PMP" relay energizes, the up valve solenoid(s) energize and the car runs in the up direction. Repeat for the down direction, ensuring that the down valve solenoid(s) energize and the car moves in the down direction.
- If the motor runs in the wrong direction, swap any 2 power leads coming into the controller at "L1, L2, L3" and check again. (Note that the phase monitor may no longer be satisfied. If it is not, swap any two wires on the phase monitor.) Input "RP" on the controller's input module will be "high" when the phasing is correct.
- If the car does not move, make sure that the proper valve solenoids are energized. (If they are not, find out why and correct.)
- Adjust the valve for smooth acceleration and deceleration rates that allow safe and comfortable movement of the elevator.

## Getting Help

- If you have followed the above procedures and are having difficulty, call and ask for customer assistance at (804)225-5530.
- Have the Virginia Controls job number (listed on the bottom right hand side of the schematic and also found on the controller data tag) and a phone number where you can be reached available before you call. The operator will take your information and have an engineer return your call.