



AC TRACTION TEMPORARY RUN MANUAL

Start Here

It is strongly recommend that you read this setup manual carefully before proceeding with the installation.

WARNING: The elevator controller must be installed by experienced field installation personnel. The field installation personnel must know and follow all the rules and regulations pertaining to the safe installation and running of elevators. Additional information for specific devices (such as the motors, door operator, etc.) is the responsibility of the manufacturers of those devices.

WARNING: This equipment is designed and built to comply with ANSI A17.1 and national electrical code and must be installed by a qualified contractor. It is the responsibility of the contractor to make sure that the final installation complies with all applicable local, state and national codes, and is installed safely.

WARNING: The 3 phase AC power supply to this equipment must come from a fused disconnect switch or circuit breaker which is sized in accordance with all applicable national, state and local electrical codes, in order to provide the necessary overload protection for the controller and motor. Incorrect motor branch circuit protection may create a hazardous condition.

WARNING: Proper grounding is vital for the safe operation of your system. Bring the ground wire to the ground stud that is labeled "GND" or "G". You must choose the proper conductor size. See national electrical code article 250-95, or the related local applicable code.

CONTROLLER MOUNTING

Mount the controller in a location that provides:

- Adequate support for the weight of the controller.
- Adequate lighting for installation and maintenance.
- Convenient access for the routing of required conduits and cables.
- Convenient access to other devices in the machine room.
- A minimum of vibration.

Controller Environment

- Keep the machine room clean. Do not install the controller in a dusty area.
- Do not install the controller in a carpeted area, or area where static electricity is a problem.
- Keep room temperature between 0°C to 50°C (32°F to 122°F), and 95% non-condensing relative humidity. Extended high temperatures will shorten the life of electronic components. Provide adequate ventilation or air-conditioning as required.
- Avoid condensation on the equipment by keeping the controller away from sources of condensation and water (such as open windows) as these can create a hazardous condition and can damage the equipment.
- Do not install the controller in a hazardous location and where excessive amounts of vapors or chemical fumes may be present.
- Make sure power line fluctuations are within $\pm 10\%$.
- High levels of radio frequency emissions may cause interference with the controller microprocessor, and produce unexpected and even dangerous results. This could be caused by hand-held communications devices used near the controller.

POWER AND MOTOR WIRING

- All wiring must be done in accordance with the national electric code and any local codes that may apply.
- Wiring must be properly sized.
- Proper grounding is imperative to insure proper and safe operation of the equipment.
- Refer to the controller schematic (usually sheet 1) to connect building power, isolation transformer (when used), and motor leads.
- If an isolation transformer is not supplied with the controller, ensure that the data label on the controller matches the building power. The drive and controller use the same voltage.
- If an isolation transformer is supplied the drive voltage should match the output of the transformer. Note that there may be different voltages to the drive and controller. Follow the wiring shown on the schematic and be sure that the correct voltages are used. Only the drive is connected to the isolation transformer. The controller is never connected to the output of the isolation transformer! The controller voltage almost always matches the building supply voltage.

CONTROLLER CONNECTIONS WITH ISOLATION TRANSFORMER

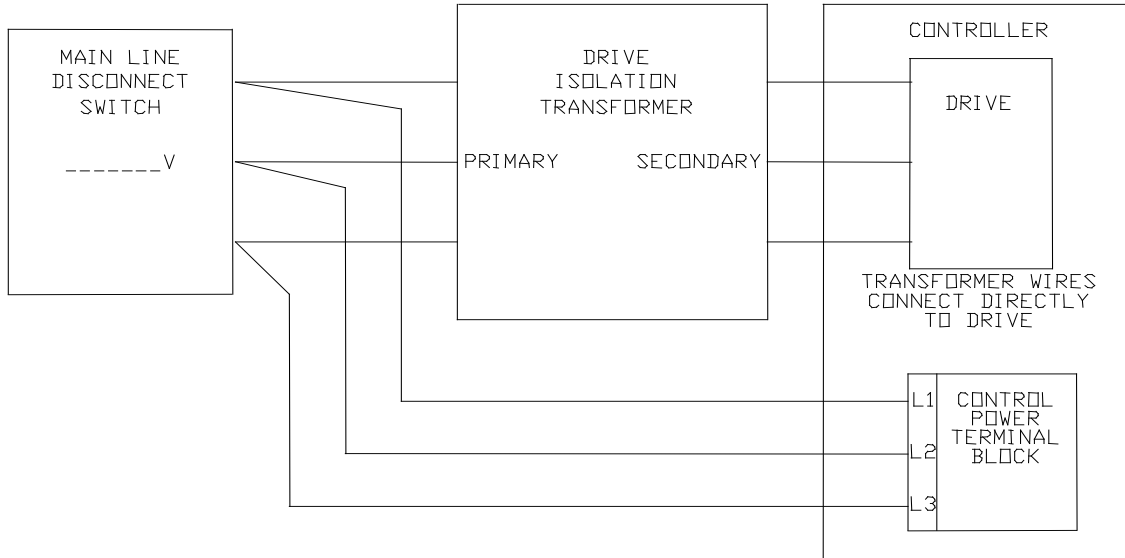

CONTROLLER CONNECTIONS WITHOUT ISOLATION TRANSFORMER

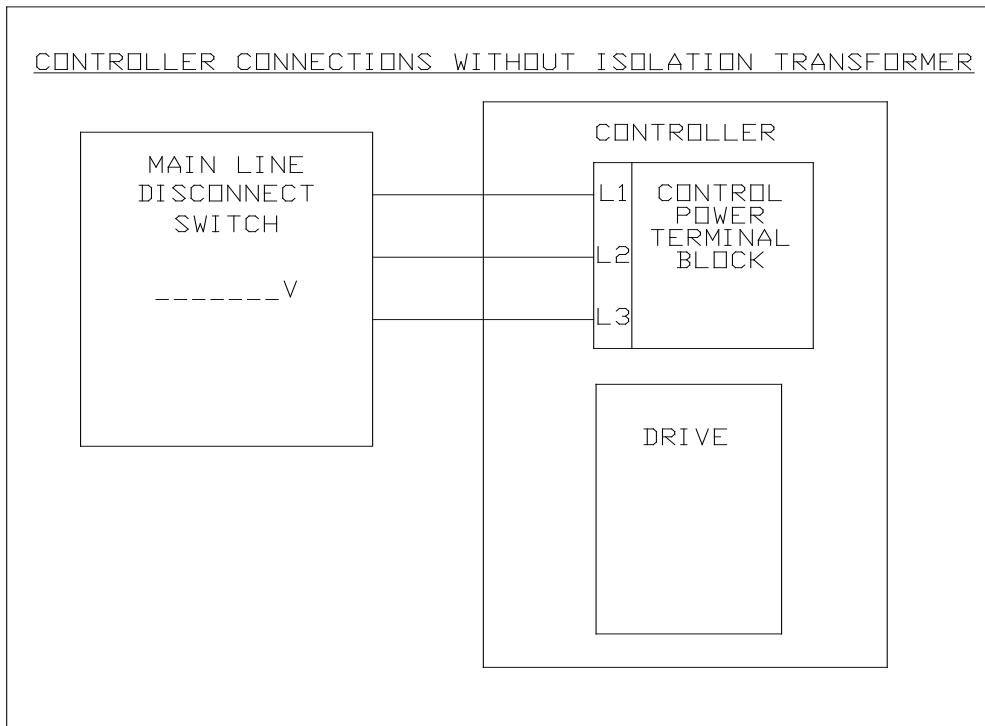

BRAKE WIRING

- Connect the brake to the controller. (Usually terminals B1 & B2)
Check the schematic (Usually sheet 2) for details.

ENCODER WIRING (CLOSED LOOP ONLY)

- The encoder must be properly mounted to the motor. It must run "true" without any wobble or play.
- Run the encoder cable in a separate conduit from the motor leads or other control wiring.
- When the encoder cable enters the controller keep it as far away as possible from contactors and high current conductors such as motor leads. The encoder cable should be as isolated as possible from all other wiring to prevent noise from entering the system.
- Connect the encoder cable directly to the drive as shown on the schematic. (Usually sheet 1) Note that some of these connections may need to be changed when the drive is first started. (Described later in this document in the section entitled "PHASING OF THE ENCODER".)
- The "Z" and "/Z" channels provided on some encoders are not required for Magnetek drives but may be needed if you have a different brand of drive. See your schematic.
- If any wires are not required be sure to insulate the ends so they cannot short to anything.
- It is very important to connect the shield as shown on the schematic.

TEMPORARY JUMPER CONNECTIONS

- Check you schematic for the location of the safety string and jump out devices as necessary. Listed below is a list of devices that generally need to be jumped out. Compare this list to your controller and make adjustments if necessary.

It is important that all of these jumpers be removed before placing the car into permanent operation.

- Additional run bug safety switches may be connected in place of some of the jumpers listed below. For example a run cord “stop switch” could be connected between terminals 2 & 2Y in place of a jumper.

DEVICE	Terminals to Jump
Finals & Governor	1W-1Y
Pit switch	1V-1W
Car top Devices	2-2Y
Firefighter’s stop switch	3-3A
Emergency Stop switch	3-3X
Car Door Contact	4B-4X
Hoistway Door Contacts	5-5X
Normal Limits & Rope Brake switch	6X-14-16
Car Top Inspection Enable Switch	1-23W
Slowdown Limit Switches	3-18-18H-18S-19-19H-19S (May not have all of these)
Emergency power	1-90 (If provided)
Fire Sensors - Main Landing Recall	1-82
Fire Sensors – Alternate Landing Recall	1-82M

The following jumpers connect directly to input modules on the microprocessor. Check your schematic for the exact location of the inputs. (Typically sheet 7) Jump from terminal 1 (120VAC power) to the inputs listed below.

HI-SPEED COUNTER Setup Input (When Provided)
ETSD Setup Input (When provided)
SHUTDOWN DEFEAT Input

To allow operation of controller inspection switches the following jumpers are also required.

Car Top Inspection Switch
Inspection Access Switch

1-23X
23Y-34Y

RUN BUG CONNECTION

Warning; It is up to the operator to ensure safe movement of the car/platform. All Safety devices were disabled in the previous steps. It is solely up to the mechanic operating the run bug to ensure that no damage or personal injury will occur when moving the car. Use extreme caution when moving the car/platform.

- Connect the "Hot" (power) side of the run bug to terminal 1.
- Connect the "UP" button to terminal 25.
- Connect the "DOWN" button to terminal 24.
- Connect any additional safety device as desired in place of temporary jumpers listed above.

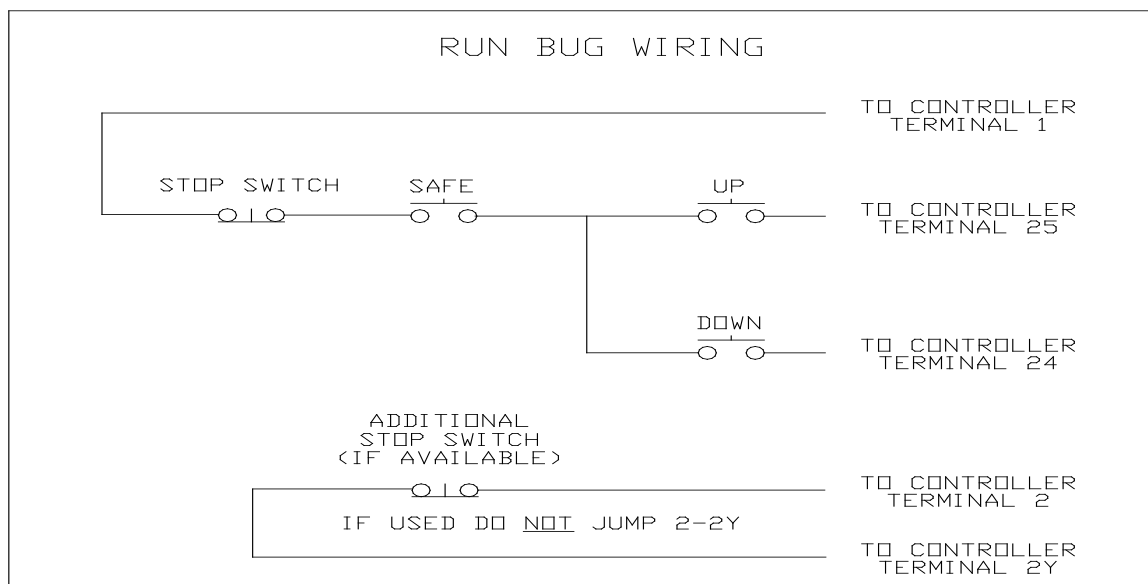

APPLYING POWER

- Remove fuses F1, F2 and F3
- Apply power to the controller.
- With a voltmeter check the voltage at terminals L1, L2 and L3. This voltage should match voltage on the controller data plate. If not, find out why and correct!
- Remove power from the controller and reinstall fuses F1, F2 and F3.
- Apply power to the controller. The microprocessor should be on, some inputs and relays may be on and the drive fans should be spinning.
- Use a voltmeter to check the voltage between terminals 1 and 35. This voltage should measure between 105VAC and 125VAC. If the voltage is outside of this range turn off the power immediately and check that the incoming voltage to the controller is correct and that the primary of transformer "CCXF" is connected for the proper voltage.

ADJUSTING THE BRAKE

- Refer to the schematic for the brake circuits (Usually sheet 2)
- Compare the brake voltage listed on the schematic to the brake data tag. These voltages should be the same.
- Power may be applied to the brake by manually pushing in contactors "BK1" and "BK2"

WARNING: The car/platform may move when the brake is picked. Do not allow any movement that may cause personal injury or damage to the equipment.

- Use a voltmeter to check for correct brake voltage(s) at terminals B1 and B2 by picking relays "BK1" & "BK2"

- Adjust the brake pick and hold voltages as needed. These values are preset at Va. Controls and should be close to the proper values. Not all brakes have a hold voltage. Refer to the schematic to see what adjustments are available via resistors "B1", "B2", Etc.
- Ensure that the brake is working mechanically.

CHECK DRIVE PARAMETERS

- Compare the motor information on the parameter sheet to the actual motor data tag. Va. Controls has predetermined the required values and they are listed on sheet "P" in the schematics. These values have already been programmed into the drive, but should be checked for accuracy. These parameters may have been changed slightly by Va. Controls, but should be very close to the data tag information on the motor. If the motor is labeled as 1800, 1200, or 900 RPM, a slightly lower value must be used.
- Compare all of the drive parameters to those listed on the parameter sheet (Sheet P) in the schematic. They should be the same. See the drive manual for information regarding using the drive programmer to access parameters.
- Check the pulses per revolution (PPR) listed on the encoder data plate. Sometimes the PPR is hidden in the part number. Generally the PPR will be either 1024 or 2048. This must be the same number that is programmed into the "encoder pulses" parameter in the drive or improper operation will occur.

RUNNING THE CAR

WARNING; ensure that the car can be moved safely without causing bodily harm or damage to the equipment.

- Use the run bug to attempt a run in the up direction. Check that the controller's up relays ("U1", "U2" etc.) energize, the brake picks and the car runs in the up direction. Repeat for the down direction, ensuring that the controllers down relays ("D1", "D2" etc.) are energized and the car moves in the down direction.
- If the car runs in the wrong direction, remove power from the controller and switch any 2 of the motor leads. After switching the motor leads run the car to see that the direction of travel is correct. The direction of travel must match the proper UP or Down Relays.
- Make sure that the brake is not dragging as the car runs. Adjust if needed.

PHASING OF THE ENCODER

Run the car and see that the motor runs smoothly in both directions and at the proper inspection speed. The motor current should now be less than the nameplate value.

- If the car runs smoothly and at the programmed inspection speed (Usually 50 FPM), no changes need to be made to the encoder phasing.
- If the car responds "sluggishly" and runs at a slow speed, the encoder phasing is generally reversed. This is also accompanied with excessive motor current. The motor current may be checked with the drive programmer. (See drive manual for exact procedure)
- To correct improper encoder phasing, remove power and reconnect the following wires.

Swap encoder wire "A" with encoder wire "B"

Swap encoder wire "/A" with encoder wire "/B"

- Apply power and test. The car should now run smoothly.

GETTING HELP

- If you have followed the above procedures and are having difficulty, call and ask for customer assistance at 804-225-5530.
- Have the Va. Controls job number (listed on the bottom right hand side of the schematic and also found on the controller data tag) and a phone number where you can be reached available before you call. The operator will take your information and have an engineer return your call.