



VIRGINIA CONTROLS

GE 9030 HYDRO CONTROLLER INSTALLATION MANUAL

Virginia Controls, Inc.
2513 Mechanicsville Turnpike, Richmond VA 23223
Tel: 804 225-5530, Fax: 804 225-0116
email: vacontrols@aol.com

PLC, Revision 1.1 6 November, 2002

Member of NAEC since 1979

TABLE OF CONTENTS

1. PRE-INSTALLATION INSTRUCTIONS AND NOTES.....	1
1.1 General Notes	1
1.2 Important Precautions And Notes.....	1
2. CONTROLLER INSTALLATION AND WIRING	2
2.1 Controller Installation.....	2
2.1.1 Controller Location Selection and Environment.....	2
2.1.2 Controller Grounding	2
2.2 Car and Hoistway Wiring	2
2.2.1 Floor Switches	2
2.2.2 Car Top Selector.....	3
2.2.3 Leveling Switches.....	3
2.2.4 Terminal Landing Normal Slowdown Switches.....	3
2.2.5 Terminal Landing Normal Limit Switches.....	3
2.2.6 Terminal Landing Final Limit Switches	3
2.2.7 Emergency Terminal Landing Limit Switch.....	3
2.2.8 Hoistway Access Zone Switches	4
2.2.9 Door Open and Close Limit Switches	4
2.3 Machine Room Wiring	4
2.3.1 Incoming Power	4
2.3.2 Grounding.....	4
2.3.3 Pump Motor Wiring	5
2.3.4 Wye-Delta Run Contact Wiring.....	5
3. START-UP INSTRUCTIONS.....	5
3.1 Before Applying Power	5
3.1.1 Power and Grounding.....	5
3.1.2 Input/Output Wiring.....	5
3.2 Applying Power.....	6
3.2.1 Motor Rotation	6
3.2.2 Pump Motor Timing	6
3.3 Temporary Run Connections.....	7
4. FINAL ADJUSTMENTS	7
4.1 Inspection Operation	7

4.2 Floor Position and Slowdown	8
4.3 Position Indicators	8
4.4 Independent Service.....	8
4.5 Car and Hall Calls.....	8
4.6 Door Operation	9
4.7 Fire Service	9
4.8 Zoned Duplex	9
4.8.1 Common Circuits	9
4.8.2 Next Car	9
4.8.3 Car Start	9
4.8.4 Homing	10
4.8.5 Communication.....	10
4.8.5.1 Communication Data	10
4.8.5.2 Example Of Communication Data.....	11
4.9 Failure Timers.....	12
4.9.1 Stuck Button Timer	12
4.9.2 Running Timers	12
4.9.3 Door Fault Timers	12
4.9.4 Door Check Circuitry.....	12
4.10 Field Adjustable Features	12
5. MICRO-PROCESSOR HARDWARE DESCRIPTION.....	13
5.1 Major Components	13
5.2 PLC Micro-Processor System	13
5.2.1 CPU	13
5.2.2 Power Supply.....	13
5.2.3 Input and Output Modules	14
5.2.4 Connections.....	14
5.2.4.1 Incoming Power Terminals	14
5.2.4.2 Programming Port.....	14
5.2.4.3 Input and Output Terminals	14
5.2.4.4 Rack Connector	14
6. CONTROLLER NOMENCLATURE	15
7. PARTS LIST	15

8. CONTROLLER DIAGNOSTICS	16
8.1 PLC Mode.....	16
8.1.1 Putting the PLC in Run Mode	17
8.2 Factory Reset	17
8.3 Change Settings	17
8.3.1 Change Settings with a Hand-Held Programmer	17
8.3.2 Change Settings with the GE Logicmaster Software	17
8.3.3 Change Settings with Jumpers	18
8.3.4 Standard Settings	19
8.3.5 Standard Features	20
8.4 Fault Logging	22
8.4.1 Examining the Fault Table with a GE Hand-held Programmer.	22
8.4.2 Fault Log Memory Addresses	23
8.4.3 Fault Codes	24
8.5 GE 9030 Hand-Held Programmer Instructions	25
8.5.1 Sequence to Check the Status of a Coil.	25
8.5.2 To Change the Value of a Register or Status of a Coil.	25
8.5.3 To Reset the Adjustable Values to the Factory Default.	25
8.5.4 To Change the DATE/TIME	25
9. TROUBLESHOOTING SUGGESTIONS	26
9.1 Locating Faults	26
9.2 I/O Board Removal	27
9.3 Factory Assistance	27
10. CONTROLLER MAINTENANCE	27
10.1 CPU Module Exchange	27
10.2 EPROM Memory Exchange.....	28
10.3 Input/Output Board Exchange	29
11. FREQUENTLY ASKED QUESTIONS	29
11.1 Questions on Field Devices.....	29
11.2 Questions on the Controller.....	30

1. Pre-Installation Instructions and Notes

1.1 General Notes

It is strongly recommend that you read this manual carefully before proceeding with the installation.

Important information is highlighted by the headings WARNING, CAUTION, or NOTE. These words are defined as follows:

WARNING - Warnings are used to indicate instructions which, if not followed correctly, will probably result in personal injury or substantial damage to equipment.

CAUTION - Cautions are used to indicate instructions or information which, if not observed, may result in some damage to equipment if care is not taken.

NOTE - Notes are used to indicate instructions or information which is especially helpful in understanding and operating the equipment, and which will usually speed up the installation process.

1.2 Important Precautions And Notes

The following general rules and safety precautions must be observed for safe and reliable operation of your system.

WARNING: IF YOU NEED TO CHANGE THE EPROM PROGRAM CHIP ON THE CPU, MAKE SURE YOU READ THE INSTRUCTIONS AND KNOW EXACTLY HOW TO INSTALL THE NEW CHIP. PLUGGING THE EPROM CHIP IN UPSIDE-DOWN MAY DAMAGE THE CHIP. STATIC ELECTRICITY CAN DAMAGE THE EPROM, SO AVOID TOUCHING THE PINS ON THE CHIP, AND GROUND YOURSELF (BY TOUCHING THE CONTROLLER CABINET) BEFORE TOUCHING THE CHIP OR THE CONTROLLER. DO NOT EXPOSE THE EPROM PROGRAM CHIP TO BRIGHT LIGHT, AND DO NOT REMOVE THE LABEL OVER THE EPROM PROGRAM CHIP WINDOW.

WARNING: THE ELEVATOR CONTROLLER MUST BE INSTALLED BY EXPERIENCED FIELD INSTALLATION PERSONNEL. THE FIELD INSTALLATION PERSONNEL MUST KNOW AND FOLLOW ALL THE RULES AND REGULATIONS PERTAINING TO THE SAFE INSTALLATION AND RUNNING OF ELEVATORS. ADDITIONAL INFORMATION FOR SPECIFIC DEVICES (SUCH AS THE VALVES, DOOR OPERATOR, ETC.) IS THE RESPONSIBILITY OF THE MANUFACTURERS OF THOSE DEVICES.

WARNING: THIS EQUIPMENT IS DESIGNED AND BUILT TO COMPLY WITH ANSI A17.1 AND NATIONAL ELECTRICAL CODE AND MUST BE INSTALLED BY A QUALIFIED CONTRACTOR. IT IS THE RESPONSIBILITY OF THE CONTRACTOR TO MAKE SURE THAT THE FINAL INSTALLATION COMPLIES WITH ALL APPLICABLE LOCAL, STATE AND NATIONAL CODES, AND IS INSTALLED SAFELY.

WARNING: THE 3 PHASE AC POWER SUPPLY TO THIS EQUIPMENT MUST COME FROM A FUSED DISCONNECT SWITCH OR CIRCUIT BREAKER WHICH IS SIZED IN ACCORDANCE WITH ALL APPLICABLE NATIONAL, STATE AND LOCAL ELECTRICAL CODES, IN ORDER TO PROVIDE THE NECESSARY OVERLOAD PROTECTION FOR THE CONTROLLER AND MOTOR. INCORRECT MOTOR BRANCH CIRCUIT PROTECTION MAY CREATE A HAZARDOUS CONDITION.

WARNING: PROPER GROUNDING IS VITAL FOR THE SAFE OPERATION OF YOUR SYSTEM. BRING THE GROUND WIRE TO THE GROUND STUD THAT IS LABELED "GND" OR "G1". YOU MUST CHOOSE THE PROPER CONDUCTOR SIZE. SEE NATIONAL ELECTRICAL CODE ARTICLE 250-95, OR THE RELATED LOCAL APPLICABLE CODE.

2. Controller Installation and Wiring

2.1 Controller Installation

2.1.1 Controller Location Selection and Environment

Mount the controller in a location that provides:

- adequate support for the weight of the controller,
- adequate lighting for installation and maintenance,
- convenient access for the routing of required conduits and cables,
- convenient access to other devices in the machine room,
- a minimum of vibration (supply additional bracing or reinforcement if required).

For improved controller reliability:

- Keep the machine room clean.
- Do not install the controller in a dusty area.
- Do not install the controller in a carpeted area, or area where static electricity is a problem.
- Keep room temperature between 0°C to 50°C (0°F to 122°F), and 95% non-condensing relative humidity. Extended high temperatures will shorten the life of electronic components. Provide adequate ventilation or air-conditioning as required if necessary.
- Avoid condensation on the equipment. Keep the controller away from sources of condensation and water (such as open windows) as these can create a hazardous condition and can damage the equipment.
- Do not install the controller in a hazardous location and where excessive amounts of vapors or chemical fumes may be present. A Nema 4 or Nema 12 rated enclosure can be provided if necessary.
- Make sure power line fluctuations are within $\pm 10\%$.
- High levels of radio frequency emissions may cause interference with the controller micro-processor, and produce unexpected and even dangerous results. This could be caused by hand-held communications devices used near the controller.

2.1.2 Controller Grounding

Grounding of the controller must conform to all applicable codes. Proper grounding is essential to the safe operation of the equipment. It will also reduce the likelihood of noise-induced problems, which could include CPU crashes, or I/O communication errors.

- The grounding wire should be sized per the applicable codes.
- Connect the ground to a good building ground, such as the structural steel of the building, or a cold water pipe.

2.2 Car and Hoistway Wiring

Review the schematics and field wiring diagrams before attempting to hook up the controller.

2.2.1 Floor Switches

The Floor Switches, if used, are normally open contacts that should close under each of the following conditions:

1. the car is at the slowdown point above the floor, OR
2. the car is at the slowdown point below the floor, OR
3. the car is at the floor (optional), OR
4. the car is between the up and down slowdown points of that landing (optional).

Conditions (1) and (2) are required to change the floor relays and initiate slowdown. Condition (3) is required at the terminal landings, but is optional at the intermediate landings. Condition (4) is optional.

There are many acceptable methods of providing the floor switch signals, such as by having a single Floor Switch at floor level, and an adjustable length cam on the car, or by having two Floor Switches per floor, and a fixed length cam

on the car. The Floor Switches may be mounted on the car if they are in separate rows. It is recommended that the method used allow for separate adjustment of the up and down slowdown distances. Recommended slowdown distance is about 6" for every 25fpm of car speed, for speeds of up to 200fpm. Minimum recommended target length for the floor switches is 1".

If there are short floors, refer to the schematic for special instructions, if required.

NOTE: The terminal landing Floor Switches must be maintained while the car is within door zone of the terminal landing.

2.2.2 Car Top Selector

The pulsing-type Car Top Selector provides Floor Change/Slowdown signals and Leveling signals, as shown on the car top selector sheet in the schematic. The signals should be a normally open contact that closes as described below.

1. UP SLOWDOWN closes at the Slowdown distance below the floor.
2. DOWN SLOWDOWN closes at the Slowdown distance above the floor.
3. UP and DOWN LEVEL, and DOOR ZONE/LOW LEVEL. (See "Leveling Sws")

NOTE: An extra reset target is required at each terminal landing, as shown on the schematic, so that the Up Slowdown Switch is closed when the car is in the leveling zone at the top landing, and the Down Slowdown Switch is closed when the car is in the leveling zone at the bottom landing. These targets are used to reset the floor position at the terminal landings.

2.2.3 Leveling Switches

The Up Level Switch is a normally open contact that closes when the car is in the leveling zone below the floor, and the Down Level Switch is a normally open contact that closes when the car is in the leveling zone above the floor. Adjust the distance between the Up Level Switch and the Down Level Switch to be equal to the length of the leveling vane/target plus the desired Dead Zone distance (usually 1/4" to 1/2"). The actual length of the leveling target is not critical (except in some short floor situations) and is usually 6-10". Position the leveling vane/target so that when the car is floor level the Up and Down Leveling Switches are centered around the vane/target, and both switches are open.

The Door Zone Switch is a switch (or switches) activated by the leveling vane/target when the car is within 3" of floor level. If the leveling vane/target is 6" long, then only one switch is required, mounted between the Up and Down Leveling Switches, otherwise two switches wired in series should be provided.

2.2.4 Terminal Landing Normal Slowdown Switches

The Terminal Landing Normal Slowdown Limit Switch is a normally closed contact that opens when the car is closer to a terminal landing than the minimum slowdown distance. It will prevent the car from running into the terminal landing at full speed. It should be adjusted to open approximately one inch beyond the point where the normal slowdown (from the floor switches or the car top selector) is initiated.

2.2.5 Terminal Landing Normal Limit Switches

The Terminal Landing Normal Limit Switch is a normally closed contact that opens when the car has traveled 1" past floor level at a terminal landing. The car should not be on the Terminal Landing Normal Limit Switch when the car is floor level at the terminal landing. The Limit Switch will prevent the car from traveling further away from the normal area of car travel, but allows the car to run back towards the normal area of car travel.

2.2.6 Terminal Landing Final Limit Switches

The Terminal Landing Final Limit Switch, where required by code, is a normally closed contact that opens when the car has gone a considerable distance beyond floor level at a terminal landing. It will prevent any further movement of the car in either direction. Consult the applicable codes for the proper setting of this switch.

2.2.7 Emergency Terminal Landing Limit Switch

The Emergency Terminal Landing Slowdown Switch should be installed as required by the applicable codes. It is a normally closed contact that opens after the car has gone beyond the Terminal Landing Normal Limit Switch.

2.2.8 Hoistway Access Zone Switches

The Hoistway Access Limit Switches limit the motion of the car on Hoistway Access, by disabling the car if it moves away from the access floor. Install the zone switches to stop the car from running down if the top of the car goes below floor level at the top access floor, and to stop the car from running up if the car goes above the second floor while on Hoistway Access at the bottom floor.

2.2.9 Door Open and Close Limit Switches

The Door Open Limit Switch is open when the doors are fully open, and closed at all other times. It will de-energize the door open relays in the door operator when the doors have opened fully.

The Door Close limit Switch is open when the doors are fully closed, and closed at all other times. It will de-energize the door close relays in the door operator when the doors have closed fully.

NOTE: Many problems in operation can be attributed to failures in the Door Open or Close Limit Switches (including long door times, improper door operation on Fire Service, inability to go on to or to clear Fire Service, etc.) Always check the Door Open and Close Limit Switches if unusual operation of the elevator is observed.

NOTE: If a solid state door operator unit is being used, check the appropriate schematics to see if any changes are required on the actual operator. These may include changing resistors in the operator, and adding a diode for proper open and close torque.

NOTE: It is recommended that the Door Close Limit Switch be adjusted so that, as the doors are closing, the Car Door Contact closes before the Door Close Limit opens. Consult the Door Operator Manufacturer's installation instructions for further details on the adjustment of the doors.

2.3 Machine Room Wiring

Mount the controller firmly and install all required conduits before wiring the controller. Note where duct has been provided in the controller for customer access, before deciding where to locate conduit openings.

WARNING: Do not allow any metal shavings to get into relays or contactors, or in or behind the electronic components, as these could cause serious damage to personnel or the equipment.

2.3.1 Incoming Power

WARNING: THE 3 PHASE AC POWER SUPPLY TO THIS EQUIPMENT MUST COME FROM A FUSED DISCONNECT SWITCH OR CIRCUIT BREAKER WHICH IS SIZED IN ACCORDANCE WITH ALL APPLICABLE NATIONAL, STATE AND LOCAL ELECTRICAL CODES, IN ORDER TO PROVIDE THE NECESSARY OVERLOAD PROTECTION FOR THE CONTROLLER AND MOTOR. INCORRECT MOTOR BRANCH CIRCUIT PROTECTION MAY CREATE A HAZARDOUS CONDITION.

Incoming AC power wiring should be done by a qualified and licensed electrician, using the appropriate size wires for the installation. Consider the motor size and type of starter, and also the length of wire required from the main power distribution center in determining the proper wire size.

Proper branch circuit protection and disconnect device(s) must be provided, as required by applicable local, state and national codes.

2.3.2 Grounding

WARNING: PROPER GROUNDING IS VITAL FOR THE SAFE OPERATION OF YOUR SYSTEM. BRING THE GROUND WIRE TO THE GROUND STUD THAT IS LABELED "GND" OR "G1". YOU MUST CHOOSE THE PROPER CONDUCTOR SIZE AND MINIMIZE THE RESISTANCE TO GROUND BY USING SHORTEST POSSIBLE ROUTING. SEE NATIONAL ELECTRICAL CODE ARTICLE 250-95, OR THE RELATED LOCAL APPLICABLE CODE.

Proper grounding is vital for the safe operation of your system, and will also reduce the likelihood of noise-induced problems, which could include CPU crashes, or I/O communication errors.

- The grounding wire should be sized per the applicable codes.
- Connect the ground to a good building ground, such as the structural steel of the building, or a cold water pipe.

- Connect the ground on the controller to the stud labeled "GND" or the terminal "G1", as shown on the controller schematic.

2.3.3 Pump Motor Wiring

Connect the pump motor as shown on sheet 1 of the schematic.

If an Across-the-Line starter is used, then the motor leads will connect to the starter overload.

If a Wye-Delta starter is used, then the motor leads will connect to the bottom of the overload, and the bottom of the STR contactor. See the schematic for specific connection details.

2.3.4 Wye-Delta Run Contact Wiring

If a Wye-Delta starter is used, an auxiliary contact of the RU contactor may be connected in series with the up valves, to prevent the car from starting to run up until the motor is in the Delta mode. If this is desired, then connect the auxiliary as shown on the schematic, sheet 1.

3. Start-Up Instructions

If it is desired to run the car temporarily, during construction, refer to the "Temporary Run Connections" section. Otherwise proceed through each of these steps and checks before applying power.

3.1 Before Applying Power

The system has been programmed and tested for the specific elevator system, so no further changes should be made without consulting with Virginia Controls.

3.1.1 Power and Grounding

WARNING: Confirm that the voltage of the incoming power matches the controller before applying power to the controller.

Check the system for improper grounds before applying power to the controller.

With the power off, remove the fuses from the secondary of the main control circuit transformer ("CCXF"). Check the safety circuit (terminals 1 through 6, and 14, 16, 18, 19) for grounds. Using a Volt-Ohm meter connect one lead to terminal 35 (ground) and touch the other lead to each terminal to be tested. The resistance should be considerably greater than 100 ohms.

NOTE: If the fuses are not removed, the meter will read a short through the windings of the main control circuit transformer.

With the fuses still removed, apply power to the controller, and verify that the voltage at the secondary of the main control circuit transformer ("CCXF") is 110-125VAC.

3.1.2 Input/Output Wiring

NOTE: The input/output boards are equipped with quick disconnect terminal blocks. During the initial installation, you may want to remove the terminal blocks, hook up your field wires to the terminal blocks, test the field wiring for no shorts to ground or hot (terminal 1) before plugging these terminals back into the I/O boards.

With the power off, and the fuses removed, check each input point for grounds, as described in the previous section, "Power and Grounding". If a ground is observed, check the schematic to determine if this is correct (it usually is NOT!).

With the power off check each output for grounds, also check for shorts to the hot side (terminal 1). Note that some field devices, such as buzzers, will have very low resistance.

WARNING: Each output point should be isolated from ground and the hot side.

3.2 Applying Power

Remove all fuses before applying power. Reinsert the fuses, one circuit at a time, checking each circuit before adding the next. Check for the proper voltage at the top of each fuseholder before installing the fuses for that circuit.

It is recommended that you start up the controller in Inspection mode, which can be done by opening the Inspection Switch, or removing the field wire(s) from terminal 23.

When power is turned on to the programmable controller the Power, OK and RUN lights on the Power Supply should come on. The program memory is prom (Programmable Read Only Memory), so does not require the battery to maintain it.

WARNING: The field wire in terminal 23 is HOT. If it is removed, make sure it is insulated and labeled. Reconnect it when the car is to be taken off Inspection Operation.

3.2.1 Motor Rotation

Check that the motor is rotating in the proper direction by turning on the power, then briefly pushing in the motor starter ("PM" on across-the-line installations, "STR" on Wye-Delta installations.). Observe the direction of rotation of the motor, and if it is incorrect, reverse any two of the main power leads at the main line disconnect.

If a Reverse Phase relay is provided, check that the OK light is on when power is applied to it. If it is not, then reverse any on the two wires connected to the A,B,C terminals.

3.2.2 Pump Motor Timing

The "PMP" relay is time delay drop out, due to the resistor/capacitor network in parallel with the coil. The purpose of the delay is to allow the Pump Motor to continue to run for a brief time (0.5 seconds) after the car has stopped, and the valves have de-energized. This allows pressure to be maintained on the hydraulic system, which prevents the car from sinking when it stops, and also allows the car to start more smoothly if it runs in the up direction on the next run. The time delay on "PMP" can be adjusted by changing the value of the capacitor in parallel with "PMP". If no time delay is required, due to the design of the valves, then the resistor and capacitor should be removed, and the diode jumped (This change is normally done in the factory if required).

"TRUP" - Run Timer. (used with Wye-Delta starters only) It is energized preset time after the motor starts to run and changes the connection of the motor from "Wye" to "Delta". An auxiliary contact of the RU contactor may be connected in series with the up valves, if desired, to prevent the car from running until the motor is up to speed. Recommended setting is 1.0 second. (see the starter sheet.)

3.3 Temporary Run Connections

The following diagram show how the car may be run on temporary service, before the controller is fully installed.

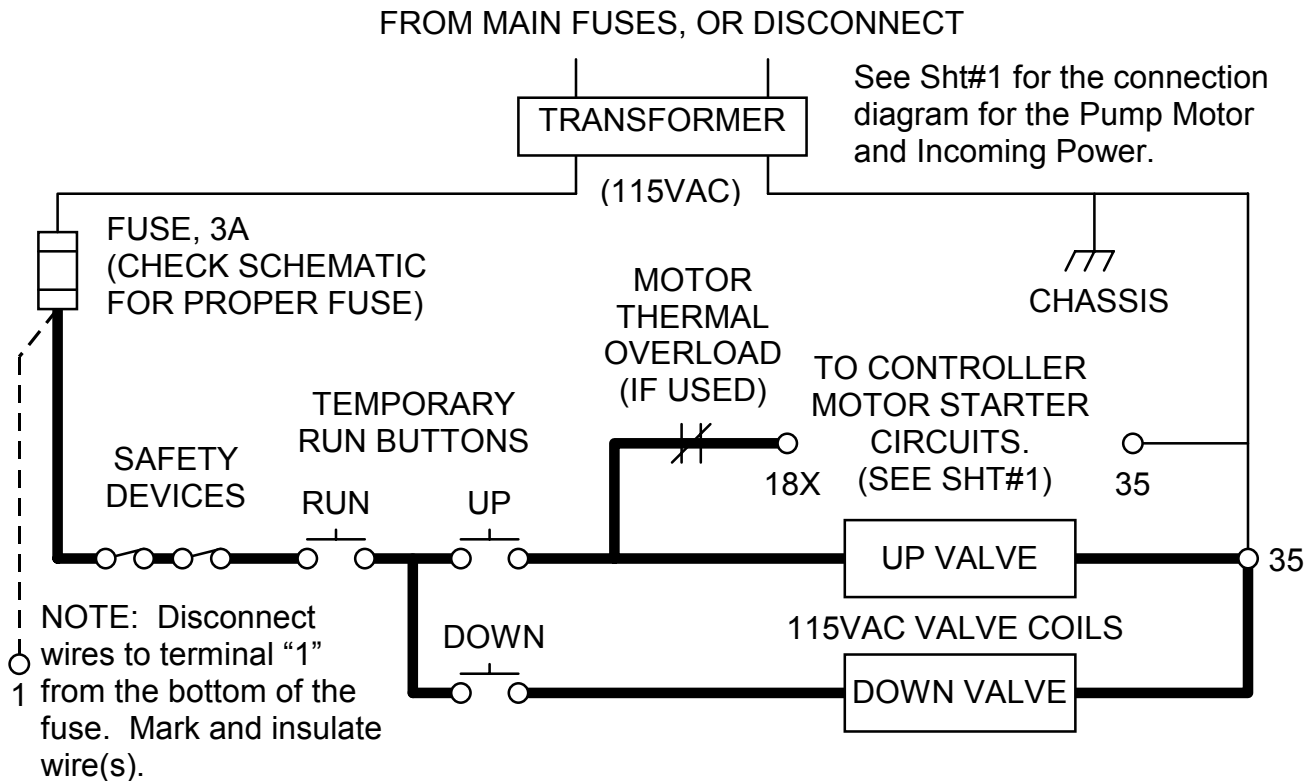

WARNING: NO SAFETY DEVICES ARE SHOWN. CONNECT ANY SAFETY DEVICES AVAILABLE IN SERIES WITH THE RUN BUTTONS, AND USE EXTREME CAUTION WHEN OPERATING THE CAR.

See the schematic for the pump motor wiring, incoming power wiring and any special requirements.

NOTE: The valves are not connected to the controller, but directly to the run buttons.

It is recommended that the wire(s) from the bottom of the fuse to terminal "1" be disconnected, marked, and insulated, to prevent any power being sent to the normal controller circuits.

When the car is sufficiently completed to allow it to be run from the inspection station, reconnect all field devices as shown on the controller schematic field sheets. Reconnect the wire(s) from terminal "1" to the bottom of the fuse (see above).

4. Final Adjustments

When the controller is ready to be run in automatic, it is recommended that a factory reset be performed. This can be done by (1) Turning off the power; (2) Put the car on inspection; (3) Jump terminals 1 to 21 and 1 to 22; (4) Turn on the power until the "Run" light on the Power Supply has come on; (5) Turn off the power, and remove the jumpers, and continue as normal.

As the wiring is completed, the following modes of operation can be checked and used.

4.1 Inspection Operation

To run the car on Inspection Operation, the safety string (including the door contacts, terminal landing normal slowdowns, normals and finals) should be operational.

The Doors Closed relay (DC) should be energized, and the corresponding input on the I/O board should be on.

The Inspection Input (normally Input A3) should be de-energized.

Pressing the Up Run and Run Buttons will energize the 1st Landing Car Call Button Input, which will cause the Up Direction and Door Close outputs to come on.

When the Doors Closed input comes on, the up run outputs for the motor and the valves will energize, and the car will run up.

(Down direction is similar)

4.2 Floor Position and Slowdown

The program is in PROM (Programmable Read Only Memory). The floor relays and fire service relays are maintained in the micro-processor RAM memory and are held through power loss by the battery in the Power Supply. The floor relays may need to be reset when the controller is initially installed. This will be accomplished when the elevator hits any floor switch. With a pulsing type selector, the floor position is reset at either terminal landing when a slowdown switch and a leveling switch are energized at the same time. Note: If floor switches are used, they should be maintained at the terminal landings, so that they are energized whenever the car is in the slowdown zone at that landing.

Make your final adjustments for the slowdown targets. All slowdown distances should be equal.

If a pulsing selector arrangement is used, remember to install the reset targets at the terminal landings.

4.3 Position Indicators

Verify that the floor position changes properly as the car goes past each landing. Floor change should take place at the slowdown point before each landing.

If the Position Indicator does not match the actual car position, run the car to a terminal landing reset target (with pulsing selector only).

4.4 Independent Service

Independent Service is useful for final tune-up of the car. Initiate Independent Service by turning on the Independent Service Switch in the car, or by jumping the Independent Service Switch input.

On Independent Service, the hall calls will be ignored. The car will run from car calls only, and will park with the doors open. To close the doors, jump terminal 1 to terminal 28 ("Door Close Button" input). This jumper may be left on, if desired, so that the car may be run by jumping the desired car call input.

NOTE: To run the car from the machine room, without the doors opening, remove the wire from the Door Open Limit Sw Input (which is usually wired to terminal 7X).

NOTE: If the car does not run, verify that no door protective device (Door Open Button, Safety Edge, Electric Eye, Infra-red Curtain) is holding the doors open. Verify that the car is not stuck in leveling. Verify that the Door Close Button input is energized.

4.5 Car and Hall Calls

To observe the operation of the car and hall calls, the system must be in automatic operation. Verify that all car and hall calls work.

NOTE: On DUPLEX systems the doors must be allowed to operate for the calls to be canceled properly.

Each call will be canceled when the car initiates slowdown for the call, or when the doors start to re-open for the call if the car is already at the floor.

If both hall calls are entered at an intermediate landing, and no other calls are in the system, the doors will close after answering one of the calls, then re-open in response to the other call.

4.6 Door Operation

Verify that any required changes to the door operator, as shown on the door operator drawings, have been made correctly.

Check the Door Open and Close Limits for proper operation.

If the doors attempt to open for too long, the open cycle will be stopped. The car will then respond to other calls, and try to open the doors again.

If the doors fail to close properly within a preset time, the doors will re-open, and try to close again. If the doors closed, but the car does not run in response to a call, the doors will re-cycle, and the car will try again.

For very slow doors, the Door Stuck Timer, which initiates the Door Open and Door Close Fail, as described above, may need to be increased. It is normally set at 15 seconds.

If Nudging Operation is activated, the Electric Eye will be disabled when the Nudging Timer has tripped AND the doors are fully open. If the nudging timer trips while the doors are closing, the Nudging Buzzer will turn on, and the Electric Eye will remain active. If the doors do reopen fully, then the Electric Eye will be cut out. The Safety Edge Input remains active on nudging.

4.7 Fire Service

Fire Service Phase 1 may be initiated by turning off a Smoke Sensor input, or by energizing the Hall Fire Switch "On" input.

Confirm that the car returns to the correct Main and Alternate landings.

Confirm that the car operates as required on Car Fire Service (Phase 2) operation.

NOTE: To reset Hall Fire Service (Phase 1), most codes require the Bypass input be energized. To disable Hall Fire Service, jump the Hall Bypass input on.

NOTE: If Car Fire Service (Phase 2) appears to be operating incorrectly, check the Door Open and Close Limits for proper operation. Most codes require that the doors be fully open before allowing a change in the mode of operation on Car Fire Service. Most codes require that Hall Fire Service (Phase 1) be in effect for the car to return automatically to the main fire landing when the Car Fire Switch is turned to the off position.

4.8 Zoned Duplex

The Duplex System will keep one car at the Main Dispatch Landing, as the Lobby Car, and allow the other car, or the Free Car, to stop at it's last call. The Lobby Car will answer calls in the Lobby Zone, and the Free Car will answer all other calls. The Lobby Car may leave the lobby to assist the Free Car under various load conditions as described below under Start Control. The "Lobby Zone" is an adjustable group of landings but the factory preset value is normally the Lobby/Main landing and any landings below the Lobby/Main landing. All other landings are in the "Upper Zone". If a car is "Next" in a zone, then it will answer calls in that zone, otherwise it will answer calls in the other zone. If both cars are in service, a car will always be homed to the Main Lobby level.

4.8.1 Common Circuits

Several circuits need to be energized when either car is on. These include the Hall Calls, Fire Service, and some other circuits that may be required for a particular job (such as Emergency Power, Hospital Service, etc.). These circuits get their power from either car by means of the VR (Voltage) relay. (See the schematic.)

4.8.2 Next Car

A "Next Car" is selected for the Lobby Zone and the Upper Zone. This car will be assigned hall calls in the respective zone. The other car may answer calls in a zone where it is not "Next", but it will not normally be sent to calls outside its zone. The "Next Car" assignments can be seen in the communication signals (see below).

4.8.3 Car Start

The Car START feature controls when the car will respond to registered Hall Calls by controlling the internal direction circuits. When the START circuit is energized the car will immediately begin to respond to Hall Calls.

There is a separate start circuit for the Lobby Zone and the Upper Zone. A car will always respond to Car Calls immediately.

The START circuit is energized if ANY of the following conditions are true:

1. The car is Next in that zone.
2. The car is in the other zone, and is NOT next in that zone. (This means that both cars are in the other zone, so the car that is not next in the other zone will be pulled into this zone.)
3. The call(s) in this zone have been registered for a preset time. (This allows the other car to help in heavy traffic situations.)
4. The car is not in normal group operation (Communication Output Point 5 will be off).
5. The other car is not in normal group operation (Communication Input Point 5 will be off).
6. The other car has a call behind it, (Communication Input Point 5 will be flashing).
7. Emergency Power is activated, and this car is assigned to run.

4.8.4 Homing

If there are no cars at the Main Dispatch landing, the "Next" car in the Lobby Zone will home, or return, to the Main Dispatch Landing. If there is no "Next Car" in the Lobby Zone, then the first available car will home to the Lobby. If desired, the "Free" car can be set up to home to a specific (adjustable) landing in the upper zone, or to home to the Main landing. (See the separate description on Feature Adjustments.)

A car will home if the following conditions have been met for 2 seconds:

1. The car is in group operation (not on Inspection, Independent Service, Fire Service, Load Weighing etc.).
2. The Stop Sw is not thrown.
3. The car is not stuck.
4. The doors are closed.
5. The car is not at the Main Dispatch Landing.
6. The car is not running.
7. The other car is in group operation.
8. The other car is not next in the Lobby Zone.
9. The other car is not running down.
10. The other car is not homing.

4.8.5 Communication

Communication between each car is achieved through the Input and Output Modules. That is, the Communication Outputs on Elevator A are connected to the Communication Inputs on Elevator B, and similarly the Communication Outputs from Elevator B are connected to the Communication Inputs on Elevator A. A Multi-plexing system is used to allow the communication of more than just the 8 Input/Output points. This operates as follows.

The Output Point 1 turns on and off regularly to sequence the data transfer. The program now can transmit two pieces of data on each output point, one piece when Point 1 is ON and one piece when Point 1 is OFF. The Microprocessor receiving data will monitor Point 1, and check the status of each other Communication Point just after Point 1 goes ON and also just after Point 1 goes off. If Point 1 is not going on and off, then the program assumes the other Microprocessor is out of service.

4.8.5.1 Communication Data

If Point 1 is ON...

And Point 2 is ON, the car is CANCELING UP HALL CALLS.

And Point 3 is ON, the car is NEXT in the UPPER ZONE.

And Point 4 is ON, the car is NEXT in the LOBBY ZONE.

And Point 5 is ON, the car has NO CALLS BEHIND IT (Back Calls).

And Point 6 is ON, the car is at Landing 1 (Binary).

And Point 7 is ON, the car is at Landing 4 (Binary).

And Point 8 is ON, the car is running on Emergency Power.

If Point 1 is OFF...

And Point 2 is ON, the car is CANCELING DOWN HALL CALLS.

And Point 3 is ON, the car is on FIRE SERVICE PHASE 2.

And Point 4 is ON, the car is HOMING, RUNNING DOWN, at the MAIN LDG, or NEXT in the Lobby Zone.

And Point 5 is ON, the car is IN SERVICE.

And Point 6 is ON, the car is at Landing 2 (Binary)

And Point 7 is ON, the car is at Landing 8 (Binary)

And Point 8 is ON, the car wants to run on Emergency Power.

NOTE 1: The Car Position, Points 6-7, is in Binary code. (Point 8 is used with more than 15 landings.) To determine the car position, add the landing values together. For example, if the car communication lights for Binary 1 and Binary 2 are both on, then the car is at the 3rd landing.

NOTE 2: If the Data light (Points 2-8) is flashing in sequence with Point 1, then the Data from the FIRST GROUP is true. If the Data light (Points 2-8) is flashing out of sequence from Point 1, then the Data from the SECOND GROUP is true. If the Data light (Points 2-8) is on all the time, then the Data from the first and second groups is true.

NOTE 3: This description applies to the operation of the Inputs and the Outputs. The Outputs will show the status of the Microprocessor for that Elevator, and the Inputs will show the status for the other Elevator.

4.8.5.2 Example Of Communication Data

Initial Conditions: There are no car calls registered. Both cars are at rest.

Elev A is at the Main (2nd) Landing, Elev B is at the 4th landing.

Elev A Communication Outputs

Elev B Communication Outputs:

#1 = flashing

#1 = flashing

#2 = off

#2 = off

#3 = off

#3 = flashing with #1

#4 = on

#4 = off

#5 = on

#5 = on

#6 = flashing opposite from #1

#6 = off

#7 = off

#7 = flashing with #1

#8 = off

#8 = off

A "1U" Hall Call is registered.

Elev A will answer this call, since it is the Lobby Zone Next car.

Communication Output changes:

Elev B: There should be no changes, since this car is not to move.

Elev A: #6 will flash with #1 when the car changes to the 1st floor.

#2 will flash with #1 when the car answers the call at the 1st landing.

Note: While Elev A is responding to the call, the following should NOT occur.

(If any of these conditions occur, then Elev B will start toward the call)

#2 should only start flashing 1 second after the car gets to the 1st floor.

#3 should not come on at all.

#4 should remain ON at all times.

#5 should remain ON at all times.

#6,#7,#8 are not critical.

To test the Hall Call Help-Out timer, put Elev B out of service while it is in the Upper Zone, but jump Elev B Communication Output Point #5 ON. Elev A will think that Elev B is still in service. Now register a hall call in the Upper Zone, and see how long Elev A takes to leave the Main Landing to respond to the call. The factory time is 30 seconds.

4.9 Failure Timers

4.9.1 Stuck Button Timer

If a car or hall call button remains on for an adjustable time, and other calls are registered, the stuck button call will be ignored, and the car will answer the other call(s). The car will return to the stuck button call as it answers other calls, and the stuck button timer sequence will be repeated.

4.9.2 Running Timers

If the car runs up for an adjustable time, without changing floors, then low oil/shutdown operation will be initiated. The Shutdown could be caused by a low oil level; a problem with the motor starter circuit(s); or a problem with the up valve circuit(s). The car will stop running up, then return to the lowest landing and cycle the doors. It will then be shut down, with only the Door Open Button and door protective devices being operational. The fault can be reset by cycling the Main Line Disconnect Switch, or by putting the car on "Inspection" then back to "Automatic". NOTE: If a Reverse Phase Relay or Emergency Power circuitry is supplied, these will also initiate a shutdown signal if the inputs are not energized.

If the car is between floors, and runs down for too long while looking for a floor, it will stop, and return to normal operation.

4.9.3 Door Fault Timers

If the doors fail to open fully after an adjustable time, the open cycle will be canceled. The door time will expire as normal, the doors will close, and the car will continue to answer calls.

If the doors fail to close after an adjustable time, the doors will reopen, and attempt to close again. The doors will be held open an adjustable time (factory set at 15 seconds) which allows the door motor to remain cool. The close cycle will be repeated until the doors close.

4.9.4 Door Check Circuitry

Door Check circuitry is an optional feature that is provided as required by the appropriate codes. A Door Contact fault condition is recognized if ALL the following conditions exist:

1. The "DC" or "DG" relay Input is energized (the car or hall doors are closed), AND
2. The Door Close Limit Input is energized (the car door is not fully closed), AND
3. The Up Level and Down Level Inputs are both off (the car is not leveling).
4. The doors are not opening or closing.

If the above fault condition exists then the fault will be initiated after 0.1 seconds. When a Door Fault is initiated, the Door Fault Output will energize and the doors will be held open. The fault is cleared when the door contacts relay input(s) go off.

When the doors are fully open, and the car is not leveling, the DOLX output will energize. This will change the connections of the car door and hall doors, so that the PLC can monitor the car and hall doors independently.

4.10 Field Adjustable Features

Refer to the section on changing Settings and Features to see the features that are adjustable.

The controller is already set up for the specific job when it is shipped from Virginia Controls. It is recommended that the "Factory Reset" sequence be performed when the controller is first powered up. This can be done by (1) Turning off the power; (2) Put the car on inspection; (3) Jump terminals 1 to 21 and 1 to 22; (4) Turn on the power until the "Run" light on the Power Supply has come on; (5) Turn off the power, and remove the jumpers, and continue as normal.

5. Micro-Processor Hardware Description

5.1 Major Components

The controller consists of the Programmable Logic Controller (PLC) Micro-Processor system, Power Supply section, and Relay Interface.

The Micro-Processor system consists of the Central Processor Board (CPU), which has the micro-processor central processing unit (the CPU may be mounted in the backplane, or may be a separate module), the EPROM memory chip (which is located in the CPU), the Power Supply, and the Input/Output boards.

The program is in EPROM (Electrically Programmable Read Only Memory). The floor relays and fire service relays are maintained in the micro-processor RAM memory and are held through power loss by the battery in the Power Supply. The floor relays may need to be reset when the controller is initially installed.

The Power Supply section includes the required transformers and fuses to power the Micro-Processor system and the Relay Interface.

The Relay Interface includes the required relays and contactors to interface the field signals and devices to the micro-processor. This usually includes a printed circuit board for normal signals, as well as other relays or contactors for signals required for each specific job.

5.2 PLC Micro-Processor System

The PLC Micro-Processor system contains the hardware that controls the inputs and outputs which control the elevator. This section describes the major components of the Micro-Processor system. The system is modular, and each module can be removed from the rack by pressing in the lever on the bottom of the module, then swinging the module up and out of the rack.

WARNING: Modules should only be removed and replaced with power to the PLC turned OFF.

5.2.1 CPU

The CPU (Central Processing Unit) is built in to the base on 5-slot and 10-slot systems, and is separate module located on the right of the Power Supply on multi-rack systems. There are no adjustments or connectors directly on the CPU.

5.2.2 Power Supply

The Power Supply plugs in to the base on the far left of each rack. It is powered by 115VAC, and provides the necessary voltages to the rest of the PLC system. There is a battery located on the front lower section of the Power Supply that maintains the status of certain registers in the CPU during a power loss. Refer to the maintenance section or the GE manual for instructions on changing the battery.

The Power Supply has a terminal strip on the left for power connections, and a 15-pin connector in the middle for a communications port that can be used with a hand-held programmer or computer for programming or monitoring functions.

The Power Supply has a set of LED lights on the upper front section. When power is applied to the Power Supply, the POWER LED will come on immediately. The OK LED should come on after the CPU performs a self-check. If it fails to come on, then check the EPROM to make sure it is inserted properly. The RUN LED should flash then stay on after the CPU finishes the self-check and goes into the run mode. If it fails to come on, there may be a fault with the system. This could be caused by a bad component (Power Supply, CPU, Input or Output Board, or EPROM chip) or by having the Input/Output boards in the wrong slots in the rack.

WARNING: If the I/O modules are switched so that an Input module is inserted where an Output Module was located (or vice-versa) then the system will not come up in the Run Mode. A hand-held programmer or computer running GE Logicmaster software may be required to get the CPU back in to the Run Mode.

There is a fuse located in the Power Supply, behind the front cover. This fuse will not normally blow, but should be checked if there is power at the terminals of the Power Supply, but none of the LEDs on the front of the Power Supply are on (There may be a slight delay on power up before the LEDs come on. This is normal.)

5.2.3 Input and Output Modules

The Input and Output modules are used to connect the PLC with the field devices. The input and output modules are available in a variety of voltages and configurations to meet the needs of the system. The most commonly used modules are 115VAC Inputs and Relay Outputs.

Each module has LED indicators to show the status of each Input or Output point. These are located on the front of the module at the top. There are two rows of LEDs, with the top row indicating the status of the first 8 points (Group A) and the lower row indicating the status of the second 8 points (Group B). When a point is on, the LED will light, and will show up as a number between 1 and 8, to indicate which point is on.

NOTE: If trouble shooting assistance is required from Virginia Controls, it is very important to get the status of all Input and Output points to help identify any possible problems.

Connections to the Input and Output modules is made by means of the removable terminal strip on the front lower half of the module. Check the schematic carefully before wiring to the module, as the location of the commons may vary from one type of module to another. The terminal blocks are removable, so BEFORE power is applied, remove the terminal blocks and check for grounds at the terminal blocks.

WARNING: Be very careful not to jump to a common when you intended to jump to an input or output, as this could damage the controller or other equipment.

Fuses are provided on the I/O board. The fuses are located on the printed circuit boards inside the modules. The outputs also have external fuses that are rated below the fuses on the modules, so the external fuse will blow first. Check the schematic for the size and name of the fuses for each output module.

The addressing for the boards is handled in the software, and is pre-programmed by Virginia Controls.

5.2.4 Connections

5.2.4.1 Incoming Power Terminals

The Incoming Power Connector is a terminal block located on the right front of the Power Supply module. The incoming power is 115VAC.

5.2.4.2 Programming Port

The Programming Port is located on the front of the Power Supply. The Hand-held Programmer is plugged in here. Also this port is used to communicate with computers or modems for programming or monitoring applications. The port supports RS422 communications, through a D15 connector.

5.2.4.3 Input and Output Terminals

Connections to the Input and Output modules is by means of a removable terminal block mounted on the front of each module. Refer to the schematic for the wiring diagram for each module.

To remove the terminal block, first press the lever at the top of the terminal block behind the swing cover. This will push the top of the block out. Then pull on the small tab at the top of the terminal block to swing the terminal block out and down. Replace the terminal block by lining up the bottom of the block then swing it up and onto the module.

5.2.4.4 Rack Connector

In multi-rack systems, each rack is connected to the rack below using a special cable. This cable is factory installed, and is plugged in to the connector at the far right of the rack.

6. Controller Nomenclature

<u>SYMBOL</u>	<u>DESCRIPTION</u>	<u>PARTS LIST ITEM NO</u>
C	DOOR CLOSE RELAY (in MODSS on top of the car, if used)	A5
DC	DOOR CLOSED RELAY (on Printed Circuit board)	A1
DL	DOWN LEVEL RELAY (on Printed Circuit board)	A1
ES	EMERGENCY STOP SWITCH RELAY (OPTIONAL) (on Printed Circuit board)	A1
ESB	EMERGENCY STOP SWITCH BY-PASS RELAY (on Printed Circuit board)	A1
FSD	FAST SPEED DOWN RUN RELAY (on Printed Circuit board)	A1
FSU	FAST SPEED UP RUN RELAY (on Printed Circuit board)	A1
IAS	INSPECTION ACCESS RELAY (on Printed Circuit board)	A1
O	DOOR OPEN RELAY (in MODSS on top of the car, if used)	A5
PM	STARTER (ACROSS THE LINE START)	B4/B7
PMP	PUMP MOTOR PILOT RELAY (110VDC) (on Printed Circuit board)	A2
RU	MOTOR RUN CONTACTOR (WYE-DELTA START)	B1/B6
STR	MOTOR START CONTACTOR (WYE-DELTA START)	B1/B6
TRU	WYE-DELTA MOTOR RUN RELAY (WYE-DELTA START)	A1
TRUP	WYE-DELTA MOTOR RUN TIMER (WYE-DELTA START)	A4
UL	UP LEVEL RELAY (on Printed Circuit board)	A1
VR	VOLTAGE RELAY (OPTIONAL) (on Printed Circuit board)	A1

7. Parts List

<u>ITEM</u>	<u>DESCRIPTION</u>	<u>MANUFACTURER</u>	<u>PART NO</u>
<u>RELAYS</u>			
A1	4PDT, 120VAC, PLUG-IN RELAY	P&B	KH 6479
A2	4PDT, 110VDC, PLUG-IN RELAY	P&B	KH 6392
A3	SURFACE MOUNT RELAY SOCKET	CUSTOM CONNECTOR	MT-14-PC
A4	TIMER, 0-102.3 SECONDS	SSAC	TDUL-3001A
A5	3PDT, 120VAC, PLUG-IN RELAY	P&B	KUP-14A35
<u>CONTACTORS, STARTERS, OVERLOAD</u>			
B1	Y-D REVERSING CONTACTOR (NEMA)	FURNAS	43__P32AAE
B2	3 POLE THERMAL OVERLOAD (NEMA)	FURNAS	48__C31AA4
B3	ACROSS-THE-LINE STARTER (NEMA)	FURNAS	14__P32AA
B4	HEATERS FOR 3 POLE OVERLOAD (NEMA)	FURNAS	H__
B5	Y-D REVERSING CONTACTOR (IEC)	TELEMECHANIQUE	(SEE
B6	ACROSS-THE-LINE STARTER (IEC)	TELEMECHANIQUE	STARTER
B7	3 POLE OVERLOAD (IEC)	TELEMECHANIQUE	SHEET)
<u>TRANSFORMERS, FUSES, TERMINALS</u>			
C1	460-230-208/230-115, 600VA	RAM	C-4797
C2	250V INSTANTANEOUS FUSE	LITTELFUSE	TYPE BLF
C3	250V FUSEHOLDER	CURTIS	PW1F
C4	TRACK FOR 250V FUSEHOLDERS	CURTIS	SW192

<u>ITEM</u>	<u>DESCRIPTION</u>	<u>MANUFACTURER</u>	<u>PART NO</u>
C5	3 POLE TERMINAL, 600V, 50AMP	CURTIS	3PSWT
C6	MOUNTING TRACK FOR TERMINALS	CURTIS	SW192

PROGRAMMABLE LOGIC CONTROLLER

D1	CPU, WITH 5 RACK	G.E.	IC693CPU311
D2	CPU, WITH 10 RACK	G.E.	IC693CPU323
D3	CPU, SEPARATE MODULE	G.E.	IC693CPU331
D4	MAIN RACK WITH 10 SLOTS	G.E.	IC693CHS391
D5	EXPANSION RACK WITH 10 SLOTS	G.E.	IC693CHS392
D6	EXPANSION RACK WITH 5 SLOTS	G.E.	IC693CHS398
D7	POWER SUPPLY	G.E.	IC693PWR321
D8	115VAC INPUT MODULE (16 POINT)	G.E.	IC693MDL240
D9	RELAY OUTPUT MODULE (16 POINT)	G.E.	IC693MDL940
D10	IN/OUTPUT MODULE (8IN/8OUT)	G.E.	IC693MAR590
D11	24VDC INPUT MODULE (8 POINT)	G.E.	IC693MDL634
D12	24VDC OUTPUT MODULE (8 POINT)	G.E.	IC693MDL733
D13	HAND-HELD PROGRAMMER	G.E.	IC693PRG300
D14	REPLACEMENT BATTERY	G.E.	IC693ACC301

SEE ALSO GE MANUAL GFK-0356 PAGES 2-1 AND 4-1

MISCELLANEOUS COMPONENTS AND HARDWARE

E1	PRINTED CIRCUIT BOARD	V.C.	MH-3
E2	PHASE MONITOR BOARD	V.C.	PMB
E3	1"W X 2"H DUCT	TAYLOR	91020
E4	1"W X 3"H DUCT	TAYLOR	91030
E5	1"W DUCT COVER	TAYLOR	99010
E6	1"W DUCT MOUNTING CLIPS	TAYLOR	08010
E7	CONTROLLER ENCLOSURE	PIEDMONT	(SIZE)
E8	STARTER ENCLOSURE	PIEDMONT	(SIZE)

All parts are commercially available from the manufacturer, or from Virginia Controls Inc. (ask for the Parts Department). Parts are subject to change without notice. Consult Virginia Controls, Inc. for current pricing information. Non-standard material is identified on the schematic.

8. Controller Diagnostics

8.1 PLC Mode

When the controller is powered up the PLC will be in the Run Mode. In this mode the PLC will allow the Inputs and Outputs to operate properly, and the elevator to run. (The only other mode is the Stop Mode, as described below. In the Stop Mode the elevator is shutdown, and all outputs are turned off.)

Trouble-shooting the controller is done by observing the status of the LEDs on the Input and Output modules, and may also be done with the GE 90-30 hand-held programmer, or GE Logicmaster software.

8.1.1 Putting the PLC in Run Mode

The PLC will normally come up in Run Mode after a power cycle. If the PLC fails to come up in the Run Mode, check that all modules are in the proper place and that all modules are fully plugged in to the rack. If a module has been swapped, a hand-held programmer may be required to restart the PLC.

A memory glitch may have put the PLC in Stop Mode, and this may be fixed by turning off power to the PLC and unplugging the battery in the Power Supply (or simply unplugging the Power Supply from the rack) for several minutes.

A faulty PLC component could prevent the PLC from coming up in the Run Mode.

The PLC can also be put in the Run Mode with the Hand-held Programmer.

1. Install the Hand-held Programmer
2. Press the "RUN" button
3. Press the "+/-" button until the display reads "Run Mode"
4. Press "Ent"

8.2 Factory Reset

This allows all settings and features to be reset to the factory values that are stored in the EPROM. This should be done on initial installation, and is recommended if the car has been left with power off for a long period of time.

1. Turn off the power
2. Turn the Inspection Switch to "Inspection" (or remove the field wire from terminal 23)
3. Jump terminals 1 to 21 and 22 (Up and Down Level Sw Inputs)
4. Turn the power back on for 10 seconds. Inputs A1 and A2 should both be ON, and Input A3 should be OFF.
5. Turn off the power
6. Remove all jumpers and put the car back on normal operation.

8.3 Change Settings

The adjustable settings are register values that can be changed with a hand-held programmer, the GE Logicmaster software, or by jumpers to Input Module 1. The sheet "FEATADJ" in the schematic gives a list of the registers that are available for adjustment, and also the default factory settings.

8.3.1 Change Settings with a Hand-Held Programmer

1. Install the Programmer. The Main Menu will be displayed. (Or press "MODE" to return to the Main Menu.)
2. Press 2 ENTER, to get into the DATA Mode.
3. Press the letter corresponding to the TYPE of coil or register to be examined or changed. (Eg: I for Input, Q for Output, M or T for Internal Coil, R for Register).
4. Enter the reference number of the coil or register to be examined, then press ENTER.
5. The desired coil or register will now be shown on the top line of the display. The value may be shown in Binary, Decimal or Hexadecimal, by pressing the HEX/DEC key to cycle through the choices. Binary is recommended for coils, and Decimal for Registers.
6. To change the value, press the RIGHT ARROW. The value will change to a flashing cursor.
7. Enter the new value. If it is a coil, enter 1 for On or 0 for Off. If it is a Register, enter the new value. Repeat steps 3-6 for all values to be changed. Timers values should be entered as tenths of a second.
8. A new coil or register may be examined by pressing the up or down arrow keys to scroll through the tables, or you may go to step 3 above and enter the desired value directly.

8.3.2 Change Settings with the GE Logicmaster Software

1. Load the software, and establish a connection with the PLC.
2. Press Alt+M to put the computer online. (Notice the status message on the bottom of the screen)
3. From the GE Logicmaster Main Menu, press "F2" for Tables.

4. Type the name of the register to display in the format: %R?? or ??R (where ?? is the register number), then press Enter.
5. The register will be displayed, showing the current value. Enter the new value.

8.3.3 Change Settings with Jumpers

NOTE: A1, B1 etc. are Input Points A1, B1, etc. on Module 1. With the terminal block removed, the pins on the Input Module correspond to the Inputs as shown in the diagram below. Terminals 1 and 35 refers to the 115VAC terminals on the main controller terminal strip.

WARNING: The car will be shutdown during this procedure. Follow these steps exactly, or incorrect data may be entered.

1. Turn off the power, and remove the terminal block from Module 1. (Press up on the latch behind the wiring door, and pull the tab to swing the terminal block out from the top.)
2. Connect a jumper from pin 19 to terminal 35 (Ground).
3. Turn the power on now, if you want to keep previously changes values. To reset all values back to the factory default, turn the power on after the next step. Wait for the Run light to come on.
4. Initiate Field Adjust Mode by energizing Inputs A1 and A2 on Input Module 1 (jump terminal 1 (Hot 115VAC) to pins 1 and 2). Turn the power on now, if it is not already on. Wait for the Run light to come on.
5. Remove jumpers to A1 and A2 (pins 1 and 2). Verify that all inputs are off on Module 1.
6. Jump terminal 1 to pins: (see table 1 below for jumpers to select proper register to be changed) Note: Leave the jumper(s) on until step 12.
7. Jump terminal 1 to pins: (see table 2 below for jumpers for desired value)
8. Momentarily jump terminal 1 to pin 1 (this will turn on Input A1).
9. Remove jumper to pin 1, then all jumpers added in step 7.
10. Jump terminal 1 to pins: (see table 2 below for jumpers for desired value)
11. Momentarily jump terminal 1 to pin 2, this will turn on Input A2.
12. Remove jumper to pin 2, then all jumpers added in step 10 and step 6.
13. Repeat steps 5-12 for all registers to be changed. End the Adjustment Mode by turning the power off, remove all jumpers to Module 1, and replace the terminal block.

Input Module Layout

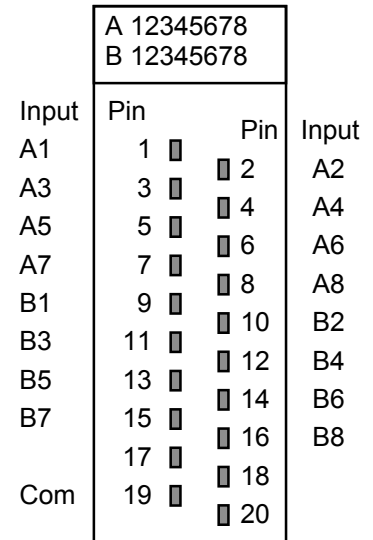

Table 1 - Jumpers For A4-A8 To Select The Register To Change. (See step 6 above)

INPUT JUMPERS					Register Number	REGISTER DESCRIPTION (Standard features shown - See FEATADJ sheet)
A4	A5	A6	A7	A8		
ON	off	off	off	off	R 65	Hall Call Door Time
off	ON	off	off	off	R 66	Car Call Door Time
ON	ON	off	off	off	R 67	Shortened Door Time
off	off	ON	off	off	R 68	Shutdown Time
ON	off	ON	off	off	R 69	Nudging Time
off	ON	ON	off	off	R 70	Electric Eye Cutout Time
ON	ON	ON	off	off	R 71	Optional Features (See The Next Sheet)
off	off	off	ON	off	R 72	Stuck Button Time
ON	off	off	ON	off	R 73	Hall Call Help Time
off	ON	off	ON	off	R 74	Door Stuck Time
ON	ON	off	ON	off	R 75	Door Stuck Reset Time
off	off	ON	ON	off	R 76	Number Of Landings
ON	off	ON	ON	off	R 77	Fire Service Main Ldg (And Duplex Main Ldg)
off	ON	ON	ON	off	R 78	Fire Service Alternate Ldg
ON	ON	ON	ON	off	R 79	(See FeatAdj sheet in schematic for Description, if used)
off	off	off	off	ON	R 80	(See FeatAdj sheet in schematic for Description, if used)
ON	off	off	off	ON	R 81	(See FeatAdj sheet in schematic for Description, if used)

off	ON	off	off	ON	R 82	Low Zone Call Delay
ON	ON	off	off	ON	R 83	Back Call Signal Delay
off	off	ON	off	ON	R 84	Bit Mask For Low Zone
ON	off	ON	off	ON	R 85	Top Zone Home Landing
off	ON	ON	off	ON	R 86	(See FeatAdj sheet in schematic for Description, if used)
ON	ON	ON	off	ON	R 87	(See FeatAdj sheet in schematic for Description, if used)
off	off	off	ON	ON	R 88	(See FeatAdj sheet in schematic for Description, if used)
ON	off	off	ON	ON	R 89	(See FeatAdj sheet in schematic for Description, if used)
off	ON	off	ON	ON	R 90	(See FeatAdj sheet in schematic for Description, if used)
ON	ON	off	ON	ON	R 91	(See FeatAdj sheet in schematic for Description, if used)
off	off	ON	ON	ON	R 92	(See FeatAdj sheet in schematic for Description, if used)
ON	off	ON	ON	ON	R 93	(See FeatAdj sheet in schematic for Description, if used)
off	ON	ON	ON	ON	R 94	(See FeatAdj sheet in schematic for Description, if used)
ON	ON	ON	ON	ON	R 95	(See FeatAdj sheet in schematic for Description, if used)

Table 2 - Jumpers For B1-B8 To Select The New Value.

Determine which jumpers need to be jumped in steps 7 and 10 to add up to the new value of the Register.
(Example: To get a new value of 500, jump pins 11,13,14,15,16 (B3,B5,B6,B7,B8) in step 7, and jump pin 9 (B1) in step 10.

Pin#	Input #	Value if jumped in step 7	Value if jumped in step 10
9	B1	1	256
10	B2	2	512
11	B3	4	1024
12	B4	8	2048
13	B5	16	4096
14	B6	32	8192
15	B7	64	16384
16	B8	128	-32768

8.3.4 Standard Settings

The following settings are standard. The settings are stored in Registers R65 to R96. Check the schematic, sheet "FEATADJ", to see which settings are used with a specific job.

- **Number of Landings** - (Usually Register R76) This is the number of landings that the controller can serve. This number should not normally be changed, since the inputs and outputs have to be assigned for the correct number of landings. If the controller is set up to serve future landings, then this value can be used to temporarily cut off future upper landings. This value also determines which floor the controller will reset to when a top landing reset is initiated with a pulsing selector.
- **Main Fire Landing** - (Usually Register R77) This is the number corresponding to the Main Fire Landing. The value set is based on the bottom floor being "1", the 2nd floor is "2" etc., even if this does not match the building designations. Normally, this is also the main landing on Duplex systems. On Simplex systems, if the Enable Homing feature is set, then the car will home to this landing. On Duplex systems, if the Enable Homing feature is set, then the free car will home to this floor as well as the lobby car.

CAUTION: If it is set to a value greater than the number of landings served, the car will go to the top landing, but it will not open its doors.

- **Alternate Fire Landing** - (Usually Register R78) This is the number corresponding to the Alternate Fire Landing. The value set is based on the bottom floor being "1", the 2nd floor is "2" etc., even if this does not match the building designations.

CAUTION: If it is set to a value greater than the number of landings served, the car will go to the top landing, but it will not open its doors.

- **Alternate Home Landing** - (Usually Register R85) This is the home landing for a simplex car or for the free car in a Duplex system, if the Enable Alternate Home Landing feature has been set. On simplexes this setting is used to home the car to a landing other than the Main Fire Landing. On Duplex systems, this setting is used

to home the free car to a specific floor, rather than leaving it at the last landing served. This value can be set to any valid landing, as determined by the number of landings setting.

- **Door Time, Hall** (in tenths of a second) - (Usually Register R65) This is the time in tenths of a second, that the doors will remain open, after they have opened fully, when the car has stopped in response to a hall call. After this time, the doors will start to close. NOTE: If a car call is entered while the doors are open, the door time will be reduced to the "Door Time, Car" setting. This setting is normally 50 tenths of a second (that is 5 seconds).
- **Door Time, Car** (in tenths of a second) - (Usually Register R66) This is the time in tenths of a second, that the doors will remain open, after they have opened fully, when the car has stopped in response to a car call only. After this time, the doors will start to close. NOTE: If a car call is entered while the doors are open, the door time will be reduced to the "Door Time, Short" setting. This setting is normally 20 tenths of a second (that is 2 seconds).
- **Door Time, Short** (in tenths of a second) - (Usually Register R67) This is the time in tenths of a second, that the doors will remain open, after they have opened fully, when the doors have reopened in response to a Door Open Button/Safety edge/Electric Eye/Infra-red Curtain, and no hall call is entered. After this time, the doors will start to close. The normal setting is 10 tenths of a second (that is 1 second)
- **Shutdown Time** (in tenths of a second) - (Usually Register R68) If the car runs up without passing a floor for this time, then shutdown will be initiated. The car will stop, and run down to the bottom landing, and cycle its doors. It will then be shut down. The car can be returned to service by cycling the Inspection Switch, or the Main Line Disconnect Sw. The normal setting is 25 seconds.
- **Door Nudging Time** (in seconds) - (Usually Register R69) This is the time delay before initiating door close nudging, if that feature is provided. A call must be registered, and the car must be in automatic operation. The timer is reset when the doors get fully closed, or when the car starts a floor to floor run. The normal setting is 25 seconds.
- **Electric Eye Cutout Time** (in seconds) - (Usually Register R70) This is the time delay before cutting out the Electric Eye Input, after it has been continuously energized. It is reset when the car runs to the next floor. The normal setting is 20 seconds.
- **Car Stuck Time** (in seconds) - (Usually Register R72) This is the time delay before calls at the same landing as the car are disabled, so that the car can answer other registered calls. This operates as a stuck button timer. The normal setting is 15 seconds.
- **Door Stalled Time** (in seconds) - (Usually Register R74) This is the time delay before stopping a door open or close cycle. The normal setting is 10 seconds
- **Door Stalled Reset Time** (in seconds) - (Usually Register R75) This is the time that the doors are held open after failing to close properly, before retrying to close. The normal setting is 10 seconds.
- **Homing Delay Time** (in seconds) - (Usually Register R79) This is the delay before homing a car to the home landing, after it has answered all calls, and is sitting with its doors closed. The normal setting is 10 seconds.
- **Call Help Time** (DUPLEX ONLY) (in seconds) - (Usually Register R73) This is the amount of time a hall call can be registered before the other car not assigned this call will respond to the call. The normal setting is 30 seconds. Decreasing this setting may cause cars to chase each other during periods of light traffic, and increasing it may cause longer waits in periods of heavy traffic.
- **Back Call Delay** (DUPLEX ONLY) (in tenths of a second) - (Usually Register R83) This is the time in tenths of a second that the back call signal will be delayed before letting the other car respond to calls behind this car. The normal setting is 10, for a time of 1 second.
- **Lobby Zone Bitmap** (DUPLEX ONLY) - (Usually Register R84) This is a bitmapped register that determines which floors are in the Lobby Zone. The first bit corresponds to the 1st landing, the 2nd bit corresponds to the second landing, etc. Landings that have their bit set are in the Lobby Zone, and will be served by the lobby car, other landings will be served by the free car.

Some installations require specific settings or features that are not included in the standard program. In this case, refer to the sheet "FEATADJ" in the schematic for a description of these settings.

8.3.5 Standard Features

The following features are standard. The features are stored as bits in register R71. Check the schematic, sheet "FEATADJ", to see which features are available and which are set with a specific job. Each feature is either on or off.

- **No Shortened Door Time** - (Usually Bit # 1) Normally the door time will be shortened by the Door Open Button/Safety Edge/Electric Eye/Infra-red Curtain. Enable this feature to prevent these devices from shortening the door time. This is normally required in nursing homes, where the passengers need more time to enter the car. The Door Close Button will still shorten the door time.
- **Timed Electric Eye Cutout** - (Usually Bit # 2) Enable this feature to allow the Electric Eye input to be disabled after the preset time (see the setting above for the delay before cutting out the Electric Eye). This feature is often provided in the Electric Eye unit itself.
- **Door Nudging** - (Usually Bit # 3) Enable this feature to activate door close nudging. Nudging will be initiated if a call is registered and the doors have been prevented from closing for the preset Door Nudging time. The Electric Eye will be disabled, the Nudging Buzzer will come on, and the Nudging Output will come on if the Electric Eye input is energized. This means the door will only close at slow speed if the Electric Eye is blocked. Note: If Reduced Speed Nudging operation is required whenever nudging is activated, then connect the Nudging Relay to the Nudging Buzzer output. Note: Door Nudging operation requires an optional Nudging Buzzer output and Reduced Speed Door Closing output.
- **One Stroke Down Lanterns** - (Usually Bit # 4) The lanterns are normally provided with two strokes for the down direction. Enable this feature to provide only one stroke for the down direction.
- **Slow Speed on Inspection** - (Usually Bit # 5) Enable this feature to run slow speed on Inspection. This is normally required if the car speed is 150fpm or above.
- **Proximity Detector** - (Usually Bit # 6) Enable this feature if a Proximity Detector (such as an infra-red curtain) is attached to the Safety Edge Input. This feature will cause the Safety Edge input to be disabled on Fire Service, and the Door Nudging feature to be initiated while the doors are closing on Fire Service. Note: Door Nudging operation requires an optional Nudging Buzzer output and Reduced Speed Door Closing output.
- **Pulsing Selector** - (Usually Bit # 7) Enable this feature if a pulsing selector arrangement is used instead of floor switches.
- **Disable Fire Service** - (Usually Bit # 8) If this feature is enabled, then Fire Service Phase 1 and 2 will be disabled.
- **Enable Duplex Operation** - (Usually Bit # 9) If this feature is enabled, then the Duplex circuitry will be enabled. Note: The controller must be set up for duplex operation.
- **Enable Alternate Landing Homing** - (Usually Bit # 10) Enable this feature to home the free car of a Duplex system, or to home a Simplex car to the Upper Home Landing when it has been idle for the adjustable Homing delay time. If this bit, and the Enable Homing bit, is not set then the car will remain where it last stopped.
- **Enable Homing** - (Usually Bit # 11) Enable this feature to enable the homing feature on a Simplex or the free car of a Duplex. This will cause the car to home to the Main Fire Landing when it has been idle for the adjustable Homing delay time. NOTE: On a Duplex, one car will always home to the Dispatch Main Landing, and, if this feature is set, then the FREE car will also home to the Dispatch Main Landing.
- **Disable Forced Reset** - (Usually Bit # 12) Enable this feature if the selector cannot provide a reset target long enough to cover the Door Zone, at the terminal landing on Pulsing Selector installations. This bit is set on PCTS (Programmable Car Top Selector) selectors, but is NOT set on IP8300 type systems. Note: In either case reset targets should be provided at the terminal landings.
- **Enable Main and Alternate Landing Resets** - (Usually Bit # 13) Enable this feature if inputs and switches are provided for Main and Alternate Landing Position Resets. If these are not provided, then Pulsing Selector systems will reset at the terminal landings only.

The following features are not standard, but may be provided as required for specific jobs. Check the schematic, sheet "FEATADJ", to see which features are available and which are set with a specific job.

- **Door Check Circuitry** - If the appropriate I/O is provided, and this feature is enabled, then the doors will be held open if the Car or Hall Door Contacts Input is energized, but the doors are still open.
- **Attendant Light Operation** - If this feature is disabled, the Attendant direction lights will show whether calls in each direction are registered, thus both direction indicator lights may be on. If this feature is enabled, the Attendant direction lights will show which direction is selected, thus only one direction indicator light will be on at a time.
- **Medical Emergency Buzzer Operation** - If this feature is disabled then the Medical Emergency Light output will come on while the car is returning to the Medical Emergency Landing. If this feature is enabled, then the Medical Emergency Light output will come on when the car is on Independent Service and a hall Medical Emergency Key Switch is turned on.

- **Fire Service Main Landing Opening** - If this feature is enabled, the Fire Service Main Landing will use the rear door if there are selective doors at that landing.
- **Fire Service Alternate Landing Opening** - If this feature is enabled, the Fire Service Alternate Landing will use the rear door if there are selective doors at that landing.
- **Single Button Collective Operation (SAPB Only)** - This feature is enabled to select Single Button Collective Operation. This is used with SAPB controllers only.
- **In Use Light Operation (SAPB Only)** - This feature is enabled to make the In Use Lights on SAPB controller operate while the doors are open or the car is running.
- **Freight Door Automatic Close Enable (SAPB Only)** - This feature is enabled to activate the Automatic Door Close outputs for freight doors on SAPB controllers. The freight door controller must have the automatic door close feature to use this feature.
- **Freight Door Automatic Close from Hall (SAPB Only)** - This feature is enabled to activate the Automatic Door Close operation from Hall Call Buttons, on SAPB controllers. The freight door controller must have the automatic closing feature to use this feature.

Some installations require specific settings or features that are not included in the standard program. In this case, refer to the "FEATADJ" sheet in the schematic to see the operation of these settings or features, and what the factory default settings are.

8.4 Fault Logging

The fault logging feature will store the last 50 faults, with all faults held through power loss. Each fault has an associated time code recorded with the fault. The faults are stored in Registers R401 to R450 (or R401 to R500 in Fault Log Version 2).

The Fault Code is the Left 2 digits of the Fault Table Value when viewed in Hexadecimal. For example, if the Fault Code Value was "0312H" then the Fault Code is "03". Compare the value in the Fault Code Value with the chart below to determine what the fault was. The Fault Codes below are in Hexadecimal.

The Fault Log Version 2 uses two registers to record the Fault Code, Time Stamp, and a Status Code that indicates the status of the elevator at the time of the fault. The codes are examined in the same way as described below, with the Fault Code in the odd numbered registers, and the associated Status Code in the next even numbered register.

8.4.1 Examining the Fault Table with a GE Hand-held Programmer.

1. Plug in the Hand-held programmer into the port on the 9030 Power Supply. It is usually best to do this with the

1.	PROGRAM
2.	DATA

POWER OFF. The Programmer will perform a self-test when power is applied, then show the Main Menu:

2. Press "2", "Enter", to go to the Data Sub-menu.
3. Press "R", "4", "0", "0", to show the status of Register R400. This is the Time Stamp Register, and it shows the current time. The number increments every 6 minutes. (Revision A Fault Logging incremented every 1 hour.) Use this value to compare with the fault codes to determine when the fault occurred.
4. Display the value in HEXADECIMAL, by pressing the "Dec/Hex" key until the display shows the Register number on the left, and the value on the right as 4 digits with an "H" after the number. For example:

R400	0013H
R401	0312H

5. The actual Fault Codes are in the Fault Table, which is Registers 401 to 450 (or 500). The most recent fault is in Register R401, followed by the next most recent in Register R402, etc. To view the faults, press the Up or Down Cursor keys to scroll through the Fault Table. In Fault Log Version 2, the most recent Fault Code is in R401, and the Status Code is in R402. The next fault is in R403 and R404, etc. Each fault entry is stored in two registers, with the Fault/Time code in the odd numbered register, and the Status Code in the next even numbered register. To view the faults, press the Up or Down Arrow keys to scroll through the table.
6. The Fault Code is the Left 2 digits when viewed in Hexadecimal. For example, if the Fault Table Value was "0312H" then the Fault Code is "03".

7. The Time Stamp is the Right 2 digits when viewed in Hexadecimal. For example, if the Fault Table Value was "0312H" then the Time Stamp is "12". The Time Stamp is a copy of Register R400 when the fault occurred, so comparing the value to the current value of Register R400 will show when the fault occurred. (In the example above, where the current Time Stamp is "0013H", and the Fault Table Value is "0312H", this means the Fault Code "03" occurred about 6 minutes ago.)

NOTE: The Time Stamp is a hexadecimal number, not a decimal number.

NOTE: Every 24 hours, the value of Register R400 will "roll over", resetting back to zero. A Fault Code of "0000H" is inserted in to the Fault Table, to indicate that faults before this code are from the previous 24 hour time period. If the Fault Table has several values of "0000H" then the car has run for several 24 hour periods without a fault.

NOTE: If power is removed from the controller, then Register R400 will not increment.

8. The Status Code (used with Fault Log Version 2 only) shows the elevator status at the time of the fault. Each bit shows a different function. Press the DEC/HEX key to change the register display mode from Decimal to Hexadecimal to Binary. Compare the bits in the bottom line of the display to determine the elevator status. (The "?" indicates the bit(s) assigned to each function)

[xxxxxxxxxxxx?????] Bits 1-5 = Floor Position as Binary Number

[xxxxxxxxxxxx?xxxxx] Bit 6 = Car had a Up Direction

[xxxxxxxxxxxx?xxxxxx] Bit 7 = Car had a Down Direction

[xxxxxxxxxx?xxxxxxxx] Bit 8 = Car was Running

[xxxxxxxx?xxxxxxxxxx] Bit 9 = Car was Running Fast Speed

[xxxxxxx?xxxxxxxxxxx] Bit 10 = Car was on a Floor-to-Floor Run

[xxxxx?xxxxxxxxxxxxx] Bit 11 = Door Contacts Input was ON

[xxxx?xxxxxxxxxxxxxx] Bit 12 = Door Close Limit Input was ON **

[xxx?xxxxxxxxxxxxxxx] Bit 13 = Door Open Limit Input was ON

[xx?xxxxxxxxxxxxxxx] Bit 14 = Up Level Switch Input was ON

[x?xxxxxxxxxxxxxxx] Bit 15 = Down Level Switch Input was ON

[?xxxxxxxxxxxxxxx] Bit 16 = Door Zone Switch Input was ON

(** Bit 12 monitors Door Locks with Freight or Manual Doors)

To view the Fault codes with the GE Logicmaster software, from the main menu press F2, for Tables. View register R400, by typing %R400 then pressing Enter. Change the registers to Hexadecimal display, by pressing F10 then F5.

8.4.2 Fault Log Memory Addresses

<u>Register Version 1</u>	<u>Register Version 2</u>	<u>Description</u>
%R400	%R400	Current Time Stamp Code. This is a number between 00 and FF(hexadecimal, or 255 decimal) that time stamp code. The number increases by one every six minutes. By subtracting the time code of a particular fault from the current time code, you can determine how fault occurred. For example, if the time code for a fault is 14, and the current time code is 16, then the occurred 2 time periods ago which is 12 minutes. Remember that the time code is a hexadecimal number decimal. To convert to a decimal number, multiply the left (most significant) digit by 16, and add to the right (least significant) digit. The letter A(hex)=10(dec), B(hex)=11(dec), C(hex)=12(dec), D(hex)=13(dec), E(hex)=14(dec), F(hex)=15(dec). Every 24 hours, the value of the current time code will roll over, resetting from "FF" to "00". A fault code "00" is inserted into the fault table, which indicates faults before this code are from an earlier 24 hour period. If power is removed from the controller, then the current time will not increment.
%R401	%R401	The most recent fault.
	%R402	Status Code for the most recent fault
%R402	%R403	The 2nd most recent fault.
	%R404	Status Code for the 2nd most recent fault
%R403	%R405	The 3rd most recent fault.
	%R406	Status Code for the 3rd most recent fault

%R404 to %R449	%R407 to %R498	The table is repeated for the rest of the fault table.
%R450	%R499	The 50th most recent fault.
	%R500	Status Code for the 50th most recent fault

8.4.3 Fault Log Codes

<u>Fault Code</u>	<u>Fault Description</u>
00	Rollover Code. This Fault Code is inserted every 24 hours to show that the faults before this code were from the previous 24 hour time period.
01	Running Shutdown Timer. The car ran for the time specified by the "Shutdown Time" setting without passing a floor. The car will stop and return to the bottom landing. It is reset by cycling power or cycling the Inspection Switch. The probable causes are: (1) Low oil. (2) Up valve(s) did not operate properly. (3) Pump did not operate properly. Check that the setting of the shutdown timer is long enough for the car to run between floors. The normal shutdown timer setting is 25 seconds.
02	Brake Fault Timer Fault. This fault is for traction elevators only. The Brake Fault Timer monitors the Brake Micro Switch Input, and other run inputs (such as BK1, BK2, P, PZ, or PX contacts) that change state when the car starts or stops. If an input fails to change state properly within 3 seconds of the start or end of a run, then the Brake Fault Timer will trip. Check the wiring and contacts going to the run inputs for proper operation. This fault will shut down the controller, and is reset by cycling power or cycling the Inspection Switch.
03	Drive Reset Fault. This fault is for traction elevators only. The drive has attempted to reset more than the preset number of times (default=4). If the drive runs for 15 minutes without a fault then the counter is reset to zero.
04	Leveling Fault. This fault is for traction elevators only. The Leveling Fault is initiated when the car has been leveling for more than 15 seconds, or if the car is oscillating at the floor, bouncing from up level to down level to up level, etc. The car is not shut down, but will not be able to relevel until the car has run to another landing.
05	Emergency Power. The car went on Emergency Power, if supplied.
06	Door Open Fault. The Door Open Limit Switch failed to open after the doors had been opening for the time specified by the "Door Fault" setting. The probable causes are: (1) The Door Open Limit failure. (2) door operator failure. (3) door control circuitry failure.
07	Door Close Fault. The doors failed to close properly when they were parking, or when the car was ready to run for the next call. This fault will not be caused by keeping the doors open through the normal means (Door Open Button, Safety Edge, Infra-red Unit, etc.), but only if the doors should be closing but were not able to close. The probable causes are: (1) Door Close Limit failure. (2) Door Contacts failure. (3) door operator failure. (4) door control circuit failure.
08	Door Contact Fault. The Door Contact Input turned off while the car was running. This fault could be caused by the car tipping a door contact, or another of the devices in the safety string. It could also be caused by a failure of the "DC" Door Contact relay.
09	Door Zone Fault. The car stopped between floors. This is normal when the car is being taken off Inspection Service. This fault will usually be seen with fault 08, since the car will usually stop outside the door zone if the safety string is broken.
0A	Car Stuck Fault. The car was held at a floor for the time set by the "Car Stuck Time" setting, without running. This may be caused by a stuck button, or just by a passenger holding the car.
0B	High Speed Counter Fault (If Used)(Available with High Speed Counter cards only). The High Speed Counter detected an overspeed condition. Possible faults include exceeding 110% of contract speed; exceeding 150fpm on Inspection; exceeding 50fpm with the doors open; loss of Tachometer signal; tachometer showed the car running the wrong direction. The specific fault will be shown on a fault output indicator, see the schematic for the location of the fault output indicators.
0C	Emergency Terminal Slowdown Detection Overspeed Fault. (If Used)(Available with High Speed Counter Card only.) An overspeed was detected at a terminal landing. The most recent overspeed fault data is stored in the ETSD fault registers, as described in the ETSD Instructions.
0D	Door Check Fault (if used). Door Contacts were closed when the Door Open Limit was broken.

- 0E Rope Brake Fault (if used). The car moved out of the Door Zone with the doors open.
- 0F Drive Ready Fault (if used). The Drive Ready Input went off.
- 10 Communication Failure on Duplex. This will occur when the power on the other car is turned off, or the other car fails to communicate properly for 5 seconds. Check the communication wiring.
- 11 Drive On Fault (if used). The Drive On input went off while the car was running. Check the drive.

8.5 GE 9030 Hand-Held Programmer Instructions

8.5.1 Sequence to Check the Status of a Coil.

1. Install the Programmer. The Main Menu will be displayed. You can return to the Main Menu by pressing MODE.
2. Press 2 ENTER, to get into the DATA Mode.
3. Press the letter corresponding to the TYPE of coil to be examined. (Eg: I for Input, Q for Output, M or T for Internal Coil, R for Register).
4. Enter the reference number of the coil to be examined, then press ENTER.
5. The desired coil will now be shown on the top line of the display. The value may be shown in Binary, Decimal or Hexadecimal, by pressing the HEX/DEC key to cycle through the choices. Binary is recommended for coils, and Decimal for Registers.
6. A new coil may be examined by pressing the up or down arrow keys to scroll through the tables, or you may go to step 4 above and enter the desired value directly.

8.5.2 To Change the Value of a Register or Status of a Coil.

1. Display the desired Register or Coil on the top line of the display as shown above. (Registers should be displayed in Decimal or Hexadecimal. Hexadecimal numbers are 4 digit numbers followed by an 'H'.)
2. Press the RIGHT ARROW. The value will change to a flashing cursor.
3. Enter the new value. If it is a coil, enter 1 for On or 0 for Off. If it is a Register, enter the new value. Repeat steps 1-3 for all values to be changed.

8.5.3 To Reset the Adjustable Values to the Factory Default.

1. Display coil M305, as described above.
2. Turn coil M305 ON, as described above. The coil will immediately be turned off by the program, but while it was on the default values were reset. This includes Door Times, Fire Service Floors, and other timer values.

8.5.4 To Change the DATE/TIME

1. With the power OFF, plug in the GE 9030 Hand-held Programmer.
2. Turn on the power.
3. Put the PLC in the STOP mode.
 - a) Press **RUN, +/-, +/-**, (Display should show "STOP"), **ENT**
 - b) The top right of the screen should show "<S" (not "<R")
4. Go to the Configuration menu
 - a) Press **MODE, 4, ENT**
5. Press the **Right Arrow** to display the current **month** setting.
 - a) Press the appropriate number(s) for the new value, then press **ENT**.
6. Press the **Right Arrow** to display the current **day** setting.
 - a) Press the appropriate number(s) for the new value, then press **ENT**.
7. Press the **Right Arrow** to display the current **year** setting.
 - a) Press the appropriate number(s) for the new value, then press **ENT**.

8. Press the **Right Arrow** to display the current **hour** setting.
 - a) Press the appropriate number(s) for the new value, then press **ENT**.
9. Press the **Right Arrow** to display the current **minute** setting.
 - a) Press the appropriate number(s) for the new value, then press **ENT**.
10. Press the **Right Arrow** to display the current **second** setting.
 - a) Press the appropriate number(s) for the new value, then press **ENT**.
11. Put the PLC in the RUN mode.
 - a) Press **RUN, +/-**, (Display should show "RUN"), **ENT**
 - b) Press **ENT** again if you are asked if you want to clear faults.
12. Press **MODE** to return to the Main Menu.
13. Unplug the Hand-held Programmer.

9. Troubleshooting Suggestions

Refer to the GE Programmable Logic Controller (PLC) Installation Manual #GFK-0356 for a complete description of hardware. Page numbers may vary depending on the revision date of the manual.

Before applying power to the programmable controller, verify that the voltage to line 1 and 35 is 110-125VAC. When power is turned on to the programmable controller the Power, OK and Run lights on the Power Supply should come on. The program memory is PROM (Programmable Read Only Memory), so does not require the battery to maintain it. The battery is required to hold some retentive coils in the CPU during a power failure. The battery has a life of between 2 and 5 years. When it is about to fail, the battery light on the power supply module will go on. The battery should now be changed as described in the GE manual (page 3-7).

To provide proper warning of a failing battery, the controller may turn on or flash the shutdown output when the battery is low. This output may be used to alert building personnel that the battery should be changed. When the controller power is off, the battery will drain quicker than if the power is on, so it is recommended that the controller power be left on whenever possible.

Field connections should be in accordance with the user's manual (page 3-39). Refer to the Virginia Controls schematic to determine which wires are connected directly to the I/O modules, and which are connected to terminals.

Note: It may be easier to connect the field wiring with either the module or the terminal board removed. (see pages 3-34 to 3-39)

Note: It is essential that all wiring is connected to the correct Input or Output point. It may be necessary to temporarily remove a factory wire from one of the I/O modules when connecting the field wiring. If this is done, be sure to return the factory wire to the correct place.

Note: The terminal numbers do not correspond to the Input/Output reference numbers. The schematic shows the terminals and the reference numbers. The indicator lights show the input/output reference numbers. The top line of lights is for Group A Inputs/Outputs, the bottom line is for group B Inputs/Outputs. See the schematic or module label to match the input/output number to the proper terminal number.

Refer to the GE Installation Manual Chapter 3 for maintenance and troubleshooting procedures. Troubleshooting is similar to any other controller, and has several features to speed up determining the cause of any problem. No special knowledge of the operation of the PLC is required to be able to troubleshoot it. A hand-held programmer is useful but not essential for troubleshooting.

A safety relay interface is provided to prevent dangerous operation due to a failure of the PLC. It is possible that the PLC may turn on an output point, yet the field safety switches may prevent the associated device from energizing. For example, if the up run output energizes, but the up normal switch is open, then the up run valve(s) will not energize.

9.1 Locating Faults

Once the system has been installed, and is running properly, the most common problem will be the failure of an external device. The first step in locating the cause is to determine whether the fault is in the micro-processor or

whether it is in the external wiring. For example, if a position indicator light is not lit, check the output module for the appropriate output point to determine if the micro-processor is trying to turn the light on or not. If the output light is on, then confirm that there is voltage at the module terminal. If there is voltage at the module terminal, then the problem is external to the micro-processor. It could be in the wiring to the position indicator, or perhaps the position indicator light has burned out. Similarly with input points, check that the input module light is on, that there is power at the terminal, and if not then the problem is external.

If it is determined that the problem is with the PLC, then the terminal block can be unplugged from the module, and a new module should be installed in its place. If this does not correct the problem, the Power Supply, Rack or the CPU module could be faulty. If the CPU fails, it will probably turn off its "Run" or "OK" light, due to internal checking features. The CPU and other modules can be affected by high transient surges in the power supply, such as the building being hit by lightning. This may damage the CPU, or alter the contents of the program. Proper grounding will protect the controller from most of these problems.

9.2 I/O Board Removal

WARNING: When replacing a board, the same type of board must be used to match the old board. Check that the replacement board has the same part number as the old board.

To replace an I/O board, unplug the terminal block. Press the lever at the bottom of the module, and pull the module forward and out. Install the new module by reversing the above steps. Refer to the user's manual (pages 3-34 and 3-35) for additional information on the proper procedure for removing input or output cards. If an Input or Output Module fails, it may be possible to temporarily replace that defective module with another module that is used for non-essential functions (such as call register lights), thus providing elevator service while a replacement module is being obtained.

Note: The Input and Output modules must be installed in the correct slots. The schematic indicates where each module should be located. Though Input modules may be changed with other Input modules of the same type, and Output modules changed with other Output modules of the same type, an Input module must never be put in a slot allocated for an Output module, and an Output module must never be put in a slot allocated for an Input module.

9.3 Factory Assistance

IMPORTANT: IF TROUBLESHOOTING ASSISTANCE IS REQUIRED FROM VIRGINIA CONTROLS, GET THE FOLLOWING INFORMATION BEFORE CALLING (ADDITIONAL TROUBLESHOOTING INSTRUCTIONS MAY BE GIVEN, DEPENDING ON THE NATURE OF THE PROBLEM):

- **THE VIRGINIA CONTROLS DRAWING NUMBER** (located at the bottom right of the schematic).
- **AN EXACT DESCRIPTION OF THE PROBLEM.**
- **THE STATUS OF ALL THE INPUT AND OUTPUT POINTS.**
- **THE STATUS OF THE LIGHTS ON THE POWER SUPPLY.**

10. Controller Maintenance

WARNING: MAKE SURE THE POWER IS OFF BEFORE CONNECTING OR DISCONNECTING ANY CONNECTORS, MODULES OR CABLES ON THE PLC OR I/O BOARDS.

10.1 CPU Module Exchange

To swap out a CPU module:

1. Turn off the power to the controller.
2. If the system has a separate CPU module, press the release lever on the bottom of the module to remove the module. Swing it out, and put in the new CPU module by reversing the procedure.
3. If the system has a CPU in the rack, then remove all modules, including the Power Supply. Unbolt the rack, and replace it with the new rack. Re-install all the modules.

10.2 EPROM Memory Exchange

WARNING: IF YOU NEED TO CHANGE THE EPROM PROGRAM CHIP ON THE CPU BOARD, MAKE SURE YOU READ THE INSTRUCTIONS AND KNOW EXACTLY HOW TO INSTALL THE NEW CHIP. PLUGGING THE EPROM IN UPSIDE-DOWN MAY DAMAGE YOUR CHIP. STATIC ELECTRICITY CAN DAMAGE THE EPROM, SO AVOID TOUCHING THE PINS ON THE CHIP, AND GROUND YOURSELF (BY TOUCHING THE CONTROLLER CABINET) BEFORE TOUCHING THE CHIP OR THE CONTROLLER. DO NOT EXPOSE THE EPROM PROGRAM CHIP TO BRIGHT LIGHT, AND DO NOT REMOVE THE LABEL OVER THE EPROM PROGRAM CHIP WINDOW.

To exchange the EPROM memory chip on the CPU board:

1. Turn off power to the controller.
2. Locate the EPROM chip. On systems with a separate CPU module, remove the CPU from the rack and remove the cover from the front of the CPU. The EPROM chip is behind the front cover on the CPU module. On systems with a built in CPU in the base, remove the three modules to the immediate right of the power supply, (the terminal blocks may be removed to make it easier to remove the modules) and locate the "Program EPROM", which is the EPROM to be changed. **WARNING: Do NOT remove the System Prom.**
3. Using a small screwdriver, or other appropriate tool, pry out the old Program EPROM chip by inserting the screwdriver between the chip and its socket. Gradually work the chip out, trying to avoid swinging it out, which would bend the pins at one end, but rather prying it straight out by working the screwdriver under the chip from both ends.
4. Insert the new EPROM chip by orienting it properly, so that the notch is at the top, to match the socket, and all the pins line up with the socket. It should not be necessary to use force to insert the EPROM chip, but apply slight sideways pressure to line up the rows of pins with the holes in the socket, then evenly press the EPROM chip into place.
5. Do not apply power until the orientation of the chip has been checked. Also verify that ALL pins are properly in the socket, and that none of them have been bent out of place.
6. Replace any modules that were removed to get to the EPROM chip. To replace a module, hook the catch at the top of the module, then swing in down to latch it
7. Turn the power back on. The new program is automatically loaded when power is applied, and the "OK" and "RUN" lights should come on. If the "RUN" light on the CPU fails to come on, then check the ORIENTATION of the PROM chip in the socket. If a Hand-Held Programmer is available, install it, then follow the instructions in the GE Manual to start the CPU. If the CPU still does not come up in the RUN mode, then the PROM chip or CPU could be miss-matched or defective. Call Virginia Controls for assistance. Please write down the CPU model number (GE # IC693CPU3??), the program number on the front of the PROM chip, and the status of the lights on the front of the CPU.
8. It may be necessary to reset the factory default settings. Check the instructions provided with the EPROM chip. To Reset Factory Default Settings, (Fire Return Landings, Door Time, etc.): Turn off the power. Put the car on Inspection (or remove field wire 23). Jump terminal 1 to terminals 21 and 22. Turn on the power. After the run light comes on for 10 seconds, turn off the power. Remove the jumpers. Turn on the power.
9. Verify the operation on Inspection, then Automatic, BEFORE allowing passengers on the car.
10. Return the old chips to Virginia Controls within 10 days. Use the plastic holder that the chips were sent in, and make sure they are carefully packed to avoid damage to the pins. The chips should be marked with the Return Authorization number shown on the paperwork with the new EPROM chips.
11. See the instruction sheet that came with the new EPROM chip for SPECIAL INSTRUCTIONS, if required.

SEPARATE CPU MODULE showing PROM CHIP LOCATION

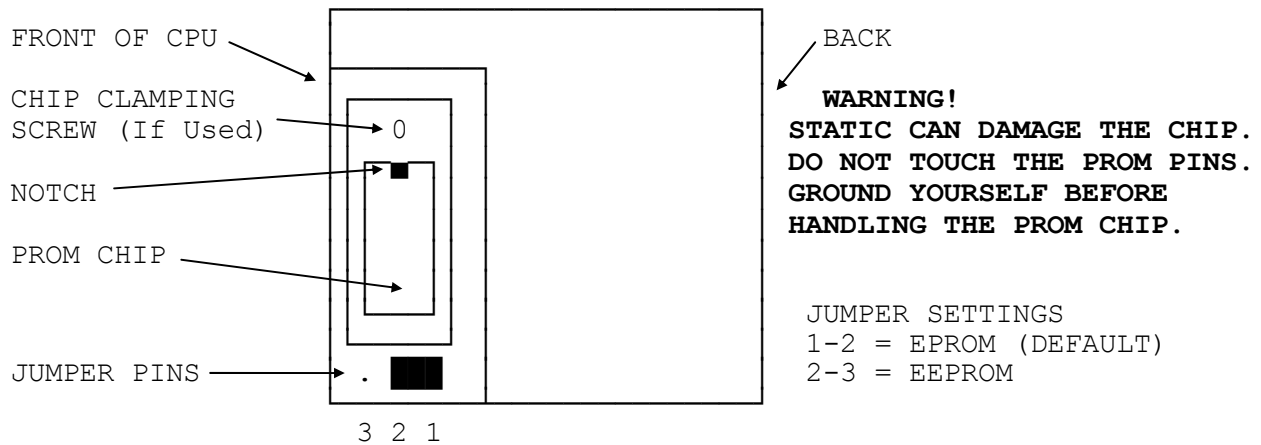

CPU RACK showing PROM CHIP LOCATION (5 SLOT SHOWN, 10 SLOT IS SIMILAR)

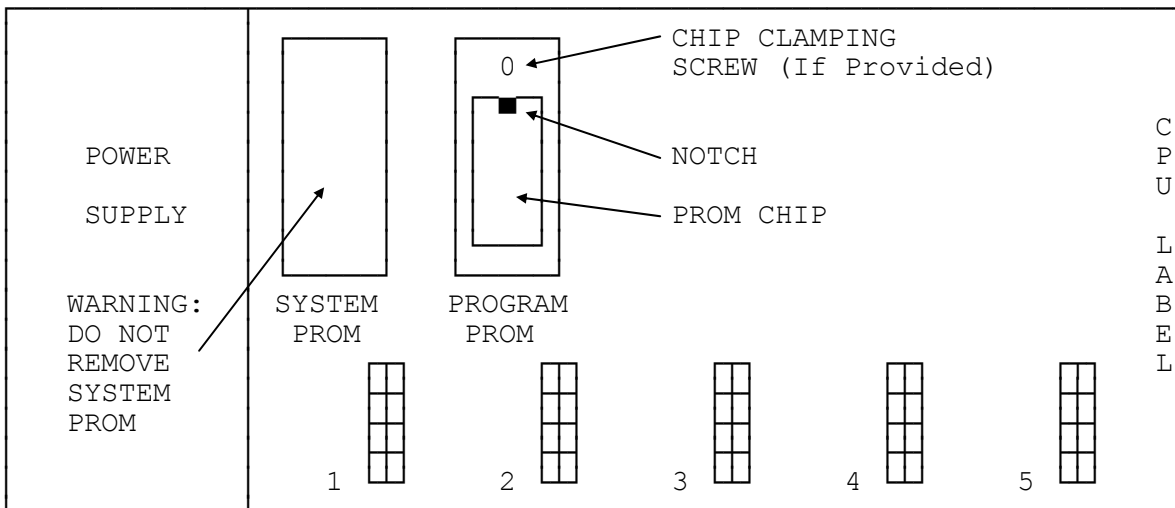

10.3 Input/Output Board Exchange

To exchange on Input or Output board:

1. Turn off the power.
2. Remove the terminal block from the module to be replaced.
3. Remove the module by pressing the lever on the bottom of the module, and swinging the module up.
4. Install the new module by reversing the previous steps.

11. Frequently Asked Questions

Suggestions for other Frequently Asked Questions are welcomed. Please submit them to Chris Wilson at Virginia Controls.

11.1 Questions on Field Devices

Q. Are the Reset Targets necessary when using a pulsing selector?

Yes.

The reset targets are required at the terminal landings, as shown on the car top selector installation sheet, to establish or reset the floor position at the terminal landings.

Q. Why are Two Position Indicators energized at the same time?

With Floor Switches, if there is an overlap of the slowdown targets, or a Floor Switch sticks on, then when the car hits a new Floor Switch, all floors that have a Floor Switch input energized will be turned on. The floor position will be corrected when the car hits the next floor switch.

If the problem happens intermittently, it is probably caused by a sticking Floor Switch. If it happens regularly at a particular floor, there is probably an overlap between Floor Switches. In this case, separate the Floor Switches (or targets) so there is no overlap.

11.2 Questions on the Controller

Q. How Do I Reset All Settings and Features Back to the Original Values?

1. Turn off the power
2. Turn the Inspection Switch to "Inspection" (or remove the field wire from terminal 23)
3. Jump terminals 1 to 21 and 22 (Up and Down Level Sw Inputs)
4. Turn the power back on for 10 seconds. Inputs A1 and A2 should both be ON, and Input A3 should be OFF.
5. Turn off the power
6. Remove all jumpers and put the car back on normal operation.

Q. How do I check the current values of the settings and features?

1. Install a hand-held programmer, or computer running GE Logicmaster software.
2. Press "2" and "ENT" to go to the data mode.
3. Press "R" and the register number that you want to check, then "ENT". Check the schematic, sheet "FEATADJ" to see the register value for the function you wan to check.
4. Press "DEC/HEX" to change the display mode to the desired mode (Decimal/Hexadecimal/Binary)
5. The register will be shown on the left, and the data in that register on the right of the display.